



LUBRICATION  
EXPERT



## **Reactive**

Corrective

“Fix it when it  
breaks”

## **Preventative**

Preventative

“Fix it at pre-  
determined intervals”

## **Predictive**

Risk-based

“Fix it when the  
problem is sensed”

## **Proactive**

Condition-based

“Fix the root cause before  
the problem event”

## Reactive

Corrective

“Fix it when it breaks”



## Preventative

Preventative

“Fix it at pre-determined intervals”



## Predictive

Risk-based

“Fix it when the problem is sensed”



## Proactive

Condition-based

“Fix the root cause before the problem event”



## Reactive

Corrective

“Fix it when it breaks”



## Preventative

Preventative

“Fix it at pre-determined intervals”



## Predictive

Risk-based

“Fix it when the problem is sensed”



## Proactive

Condition-based

“Fix the root cause before the problem event”



## Reactive

Corrective

“Fix it when it breaks”

## Preventative

Preventative

“Fix it at pre-determined intervals”

## Predictive

Risk-based

“Fix it when the problem is sensed”

## Proactive

Condition-based

“Fix the root cause before the problem event”

Fluid Condition

Contamination

Wear Information

## Predictive

Risk-based

“Fix it when the problem is sensed”

Wear Information

## Proactive

Condition-based

“Fix the root cause before the problem event”

Contamination

Fluid Condition

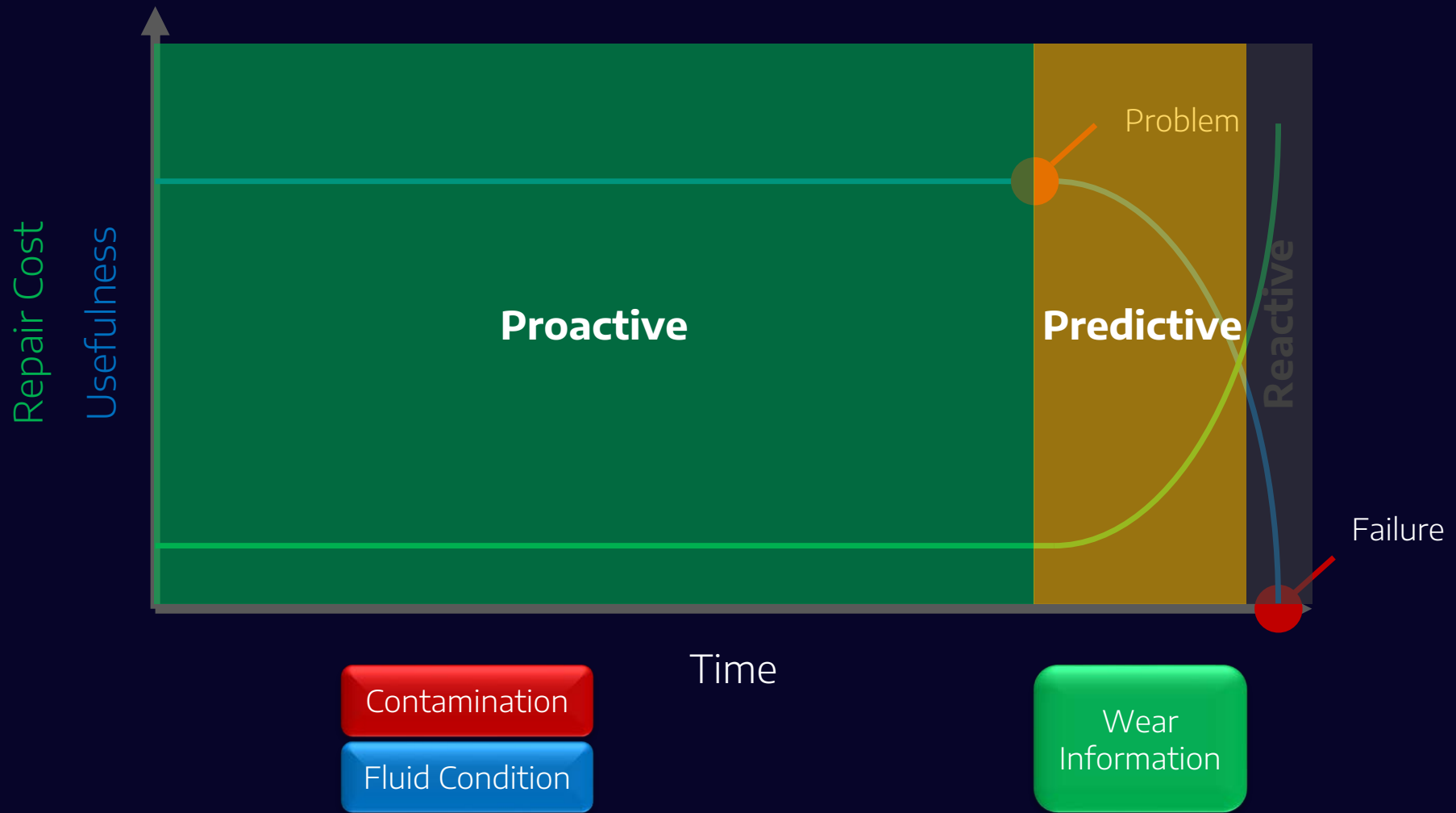

Repair Cost  
Usefulness

**Proactive**

**Predictive**

Reactive

Problem

Failure

Time

Contamination

Fluid Condition

Wear  
Information



# Reading the Report

# Sample Information

Overall Report Status = NORMAL						
Sample Info	Report Status	Caution	Normal	Normal	Alert	Normal
	Sample ID	156989048	156989060	156989101	156989206	156989348
	Bottle ID	s989048	s89060	s989101	s89206	s989348
	Lubricant	XYZ	XYZ	XYZ	XYZ	XYZ
	Sample Date	09-08-19	09-09-19	09-10-19	09-12-19	09-01-20
	Report Date	19-08-19	19-09-19	19-10-19	19-12-19	19-01-20
	Equipment Age	54206	54300	54758	54862	55001
	Equipment UOM	Hours	Hours	Hours	Hours	Hours
	Oil Changed	Yes	No	No	Yes	No
	Oil Age	486	97	299	525	141
	Oil UOM	Hours	Hours	Hours	Hours	Hours
	Make Up Volume				160	
	Volume UOM				Litres	
	Filter Changed	Yes	No	No	Yes	No
Lubricant	Contamination Rating	Caution	Normal	Normal	Alert	Normal
	Equipment Rating	Normal	Normal	Normal	Normal	Normal
	Oil Rating	Normal	Normal	Normal	Caution	Normal
	PQ Index	1	1	0	5	4
	SAE Grade	40	40	40	40	40
	Visc @100C	15.2	14.2	14.8	15.9	15.2
	Oxidation (Abs/cm)	9	6	8	13	8
	TAN (mg KOH/g)	2.39	1.66	2.31	3.02	2.25
	Nitration (Abs/cm)	1	1	1	3	3
	TBN (mg KOH/g)	8.3	9.0	8.4	7.7	8.5
	Soot (wt%)	0.13	0.11	0.15	0.19	0.19
	Water (vol%)	Not Detected	Not Detected	Not Detected	Not Detected	Not Detected
	Coolant Indicator	Not Detected	Not Detected	Not Detected	Not Detected	Not Detected
Cl (Cl ppm - Xray)	104	50	85	104	47	
Wear (ppm)	Ag (Silver)	0	0	0	0	0
	Al (Aluminium)	3	2	2	4	2
	Cr (Chromium)	0	0	0	1	0
	Cu (Copper)	2	1	1	2	1
	Fe (Iron)	7	4	4	10	7
	Mo (Molybdenum)	4	4	3	0	1
	Ni (Nickel)	1	1	1	2	1
	Pb (Lead)	2	0	1	4	0
Contaminant (ppm)	Sn (Tin)	2	0	1	2	1
	Ti (Titanium)	0	0	0	0	0
	K (Potassium)	0	0	0	0	0
Additive (ppm)	Na (Sodium)	4	4	4	8	7
	Si (Silicon )	177	76	112	248	81
	B (Boron)	1	0	0	1	0
	Ba (Barium)	0	0	0	0	0
	Ca (Calcium)	4085	3914	3790	4379	3767
	Mg (Magnesium)	11	11	11	13	11
	P (Phosphorous)	4	4	3	5	5
	Zn (Zinc)	3	3	3	4	3

## Sample Information

Overall Report Status = NORMAL						
Report Status	Caution	Normal	Normal	Alert	Normal	
Sample ID	156989048	156989060	156989101	156989206	156989348	
Bottle ID	s989048	s89060	s989101	s89206	s989348	
Lubricant	XYZ	XYZ	XYZ	XYZ	XYZ	
Sample Date	09-08-19	09-09-19	09-10-19	09-12-19	09-01-20	
Report Date	19-08-19	19-09-19	19-10-19	19-12-19	19-01-20	
Equipment Age	54206	54300	54758	54862	55001	
Equipment UOM	Hours	Hours	Hours	Hours	Hours	
Oil Changed	Yes	No	No	Yes	No	
Oil Age	486	97	299	525	141	
Oil UOM	Hours	Hours	Hours	Hours	Hours	
Make Up Volume				160		
Volume UOM				Litres		
Filter Changed	Yes	No	No	Yes	No	

## Fluid Condition

## Oil Parameters

Contamination Rating	Caution	Normal	Normal	Alert	Normal
Equipment Rating	Normal	Normal	Normal	Normal	Normal
Oil Rating	Normal	Normal	Normal	Caution	Normal
PQ Index	1	1	0	5	4
SAE Grade	40	40	40	40	40
Visc @100C	15.2	14.2	14.8	15.9	15.2
Oxidation (Abs/cm)	9	6	8	13	8
TAN (mg KOH/g)	2.39	1.66	2.31	3.02	2.25
Nitration (Abs/cm)	1	1	1	3	3
TBN (mg KOH/g)	8.3	9.0	8.4	7.7	8.5
Soot (wt%)	0.13	0.11	0.15	0.19	0.19
Water (vol%)	Not Detected	Not Detected	Not Detected	Not Detected	Not Detected
Coolant Indicator	Not Detected	Not Detected	Not Detected	Not Detected	Not Detected
Cl (Cl ppm - Xray)	104	50	85	104	47

Wear (ppm)	Ag (Silver)	0	0	0	0	0
	Al (Aluminium)	3	2	2	4	2
	Cr (Chromium)	0	0	0	1	0
	Cu (Copper)	2	1	1	2	1
	Fe (Iron)	7	4	4	10	7
	Mo (Molybdenum)	4	4	3	0	1
	Ni (Nickel)	1	1	1	2	1
	Pb (Lead)	2	0	1	4	0
	Sn (Tin)	2	0	1	2	1
Contaminant (ppm)	Ti (Titanium)	0	0	0	0	0
	K (Potassium)	0	0	0	0	0
	Na (Sodium)	4	4	4	8	7
Additive (ppm)	Si (Silicon)	177	76	112	248	81
	B (Boron)	1	0	0	1	0
	Ba (Barium)	0	0	0	0	0
	Ca (Calcium)	4085	3914	3790	4379	3767
	Mg (Magnesium)	11	11	11	13	11
	P (Phosphorous)	4	4	3	5	5
	Zn (Zinc)	3	3	3	4	3

# Sample Information

Overall Report Status = NORMAL						
Sample Info	Report Status	Caution	Normal	Normal	Alert	Normal
	Sample ID	156989048	156989060	156989101	156989206	156989348
	Bottle ID	s989048	s89060	s989101	s89206	s989348
	Lubricant	XYZ	XYZ	XYZ	XYZ	XYZ
	Sample Date	09-08-19	09-09-19	09-10-19	09-12-19	09-01-20
	Report Date	19-08-19	19-09-19	19-10-19	19-12-19	19-01-20
	Equipment Age	54206	54300	54758	54862	55001
	Equipment UOM	Hours	Hours	Hours	Hours	Hours
	Oil Changed	Yes	No	No	Yes	No
	Oil Age	486	97	299	525	141
	Oil UOM	Hours	Hours	Hours	Hours	Hours
	Make Up Volume				160	
	Volume UOM				Litres	
	Filter Changed	Yes	No	No	Yes	No
	Lubricant	Contamination Rating	Caution	Normal	Normal	Alert
Equipment Rating		Normal	Normal	Normal	Normal	Normal
Oil Rating		Normal	Normal	Normal	Caution	Normal
PQ Index		1	1	0	5	4
SAE Grade		40	40	40	40	40
Visc @100C		15.2	14.2	14.8	15.9	15.2
Oxidation (Abs/cm)		9	6	8	13	8
TAN (mg KOH/g)		2.39	1.66	2.31	3.02	2.25
Nitration (Abs/cm)		1	1	1	3	3
TBN (mg KOH/g)		8.3	9.0	8.4	7.7	8.5
Soot (wt%)		0.13	0.11	0.15	0.19	0.19
Water (vol%)		Not Detected	Not Detected	Not Detected	Not Detected	Not Detected
Coolant Indicator		Not Detected	Not Detected	Not Detected	Not Detected	Not Detected
Cl (Cl ppm - Xray)		104	50	85	104	47
Wear (ppm)		Ag (Silver)	0	0	0	0
	Al (Aluminium)	3	2	2	4	2
	Cr (Chromium)	0	0	0	1	0
	Cu (Copper)	2	1	1	2	1
	Fe (Iron)	7	4	4	10	7
	Mo (Molybdenum)	4	4	3	0	1
	Ni (Nickel)	1	1	1	2	1
	Pb (Lead)	2	0	1	4	0
	Sn (Tin)	2	0	1	2	1
Ti (Titanium)	0	0	0	0	0	
Contaminant (ppm)	K (Potassium)	0	0	0	0	0
	Na (Sodium)	4	4	4	8	7
	Si (Silicon)	177	76	112	248	81
Additive (ppm)	B (Boron)	1	0	0	1	0
	Ba (Barium)	0	0	0	0	0
	Ca (Calcium)	4085	3914	3790	4379	3767
	Mg (Magnesium)	11	11	11	13	11
	P (Phosphorous)	4	4	3	5	5
	Zn (Zinc)	3	3	3	4	3

Fluid Condition

# Oil Parameters

Wear Information

# Wear

## Sample Information

Overall Report Status = NORMAL						
Sample Info	Report Status	Caution	Normal	Normal	Alert	Normal
	Sample ID	156989048	156989060	156989101	156989206	156989348
	Bottle ID	s989048	s89060	s989101	s89206	s989348
	Lubricant	XYZ	XYZ	XYZ	XYZ	XYZ
	Sample Date	09-08-19	09-09-19	09-10-19	09-12-19	09-01-20
	Report Date	19-08-19	19-09-19	19-10-19	19-12-19	19-01-20
	Equipment Age	54206	54300	54758	54862	55001
	Equipment UOM	Hours	Hours	Hours	Hours	Hours
	Oil Changed	Yes	No	No	Yes	No
	Oil Age	486	97	299	525	141
	Oil UOM	Hours	Hours	Hours	Hours	Hours
	Make Up Volume				160	
	Volume UOM				Litres	
	Filter Changed	Yes	No	No	Yes	No
	Lubricant	Contamination Rating	Caution	Normal	Normal	Alert
Equipment Rating		Normal	Normal	Normal	Normal	Normal
Oil Rating		Normal	Normal	Normal	Caution	Normal
PQ Index		1	1	0	5	4
SAE Grade		40	40	40	40	40
Visc @100C		15.2	14.2	14.8	15.9	15.2
Oxidation (Abs/cm)		9	6	8	13	8
TAN (mg KOH/g)		2.39	1.66	2.31	3.02	2.25
Nitration (Abs/cm)		1	1	1	3	3
TBN (mg KOH/g)		8.3	9.0	8.4	7.7	8.5
Soot (wt%)		0.13	0.11	0.15	0.19	0.19
Water (vol%)		Not Detected	Not Detected	Not Detected	Not Detected	Not Detected
Coolant Indicator		Not Detected	Not Detected	Not Detected	Not Detected	Not Detected
Cl (Cl ppm - Xray)		104	50	85	104	47
Wear (ppm)		Ag (Silver)	0	0	0	0
	Al (Aluminium)	3	2	2	4	2
	Cr (Chromium)	0	0	0	1	0
	Cu (Copper)	2	1	1	2	1
	Fe (Iron)	7	4	4	10	7
	Mo (Molybdenum)	4	4	3	0	1
	Ni (Nickel)	1	1	1	2	1
	Pb (Lead)	2	0	1	4	0
	Sn (Tin)	2	0	1	2	1
	Ti (Titanium)	0	0	0	0	0
Contaminant (ppm)	K (Potassium)	0	0	0	0	0
	Na (Sodium)	4	4	4	8	7
	Si (Silicon)	177	76	112	248	81
Additive (ppm)	B (Boron)	1	0	0	1	0
	Ba (Barium)	0	0	0	0	0
	Ca (Calcium)	4085	3914	3790	4379	3767
	Mg (Magnesium)	11	11	11	13	11
	P (Phosphorous)	4	4	3	5	5
	Zn (Zinc)	3	3	3	4	3

Fluid Condition

## Oil Parameters

Wear Information

## Wear

Contamination

## Contaminants

# Sample Information

Overall Report Status = NORMAL						
Sample Info	Report Status	Caution	Normal	Normal	Alert	Normal
	Sample ID	156989048	156989060	156989101	156989206	156989348
	Bottle ID	s989048	s89060	s989101	s89206	s989348
	Lubricant	XYZ	XYZ	XYZ	XYZ	XYZ
	Sample Date	09-08-19	09-09-19	09-10-19	09-12-19	09-01-20
	Report Date	19-08-19	19-09-19	19-10-19	19-12-19	19-01-20
	Equipment Age	54206	54300	54758	54862	55001
	Equipment UOM	Hours	Hours	Hours	Hours	Hours
	Oil Changed	Yes	No	No	Yes	No
	Oil Age	486	97	299	525	141
	Oil UOM	Hours	Hours	Hours	Hours	Hours
	Make Up Volume				160	
	Volume UOM				Litres	
	Filter Changed	Yes	No	No	Yes	No
Lubricant	Contamination Rating	Caution	Normal	Normal	Alert	Normal
	Equipment Rating	Normal	Normal	Normal	Normal	Normal
	Oil Rating	Normal	Normal	Normal	Caution	Normal
	PQ Index	1	1	0	5	4
	SAE Grade	40	40	40	40	40
	Visc @100C	15.2	14.2	14.8	15.9	15.2
	Oxidation (Abs/cm)	9	6	8	13	8
	TAN (mg KOH/g)	2.39	1.66	2.31	3.02	2.25
	Nitration (Abs/cm)	1	1	1	3	3
	TBN (mg KOH/g)	8.3	9.0	8.4	7.7	8.5
	Soot (wt%)	0.13	0.11	0.15	0.19	0.19
	Water (vol%)	Not Detected	Not Detected	Not Detected	Not Detected	Not Detected
	Coolant Indicator	Not Detected	Not Detected	Not Detected	Not Detected	Not Detected
	Cl (Cl ppm - Xray)	104	50	85	104	47
Wear (ppm)	Ag (Silver)	0	0	0	0	0
	Al (Aluminium)	3	2	2	4	2
	Cr (Chromium)	0	0	0	1	0
	Cu (Copper)	2	1	1	2	1
	Fe (Iron)	7	4	4	10	7
	Mo (Molybdenum)	4	4	3	0	1
	Ni (Nickel)	1	1	1	2	1
	Pb (Lead)	2	0	1	4	0
	Sn (Tin)	2	0	1	2	1
Ti (Titanium)	0	0	0	0	0	
Contaminant (ppm)	K (Potassium)	0	0	0	0	0
	Na (Sodium)	4	4	4	8	7
	Si (Silicon)	177	76	112	248	81
Additive (ppm)	B (Boron)	1	0	0	1	0
	Ba (Barium)	0	0	0	0	0
	Ca (Calcium)	4085	3914	3790	4379	3767
	Mg (Magnesium)	11	11	11	13	11
	P (Phosphorous)	4	4	3	5	5
	Zn (Zinc)	3	3	3	4	3

Fluid Condition

Wear Information

Contamination

Fluid Condition

# Oil Parameters

# Wear

# Contaminants

# Additives

# Lvl 1: Traffic Lights

Overall Report Status = NORMAL						
Sample Info	Report Status	Caution	Normal	Normal	Alert	Normal
	Sample ID	156989048	156989060	156989101	156989206	156989348
	Bottle ID	s989048	s89060	s989101	s89206	s989348
	Lubricant	XYZ	XYZ	XYZ	XYZ	XYZ
	Sample Date	09-08-19	09-09-19	09-10-19	09-12-19	09-01-20
	Report Date	19-08-19	19-09-19	19-10-19	19-12-19	19-01-20
	Equipment Age	54206	54300	54758	54862	55001
	Equipment UOM	Hours	Hours	Hours	Hours	Hours
	Oil Changed	Yes	No	No	Yes	No
	Oil Age	486	97	299	525	141
	Oil UOM	Hours	Hours	Hours	Hours	Hours
	Make Up Volume				160	
	Volume UOM				Litres	
	Filter Changed	Yes	No	No	Yes	No
Lubricant	Contamination Rating	Caution	Normal	Normal	Alert	Normal
	Equipment Rating	Normal	Normal	Normal	Normal	Normal
	Oil Rating	Normal	Normal	Normal	Caution	Normal
	PQ Index	1	1	0	5	4
	SAE Grade	40	40	40	40	40
	Visc @100C	15.2	14.2	14.8	15.9	15.2
	Oxidation (Abs/cm)	9	6	8	13	8
	TAN (mg KOH/g)	2.39	1.66	2.31	3.02	2.25
	Nitration (Abs/cm)	1	1	1	3	3
	TBN (mg KOH/g)	8.3	9.0	8.4	7.7	8.5
	Soot (wt%)	0.13	0.11	0.15	0.19	0.19
	Water (vol%)	Not Detected	Not Detected	Not Detected	Not Detected	Not Detected
Coolant Indicator	Not Detected	Not Detected	Not Detected	Not Detected	Not Detected	
Cl (Cl ppm - Xray)	104	50	85	104	47	
Wear (ppm)	Ag (Silver)	0	0	0	0	0
	Al (Aluminium)	3	2	2	4	2
	Cr (Chromium)	0	0	0	1	0
	Cu (Copper)	2	1	1	2	1
	Fe (Iron)	7	4	4	10	7
	Mo (Molybdenum)	4	4	3	0	1
	Ni (Nickel)	1	1	1	2	1
	Pb (Lead)	2	0	1	4	0
	Sn (Tin)	2	0	1	2	1
Ti (Titanium)	0	0	0	0	0	
Contaminant (ppm)	K (Potassium)	0	0	0	0	0
	Na (Sodium)	4	4	4	8	7
	Si (Silicon )	177	76	112	248	81
Additive (ppm)	B (Boron)	1	0	0	1	0
	Ba (Barium)	0	0	0	0	0
	Ca (Calcium)	4085	3914	3790	4379	3767
	Mg (Magnesium)	11	11	11	13	11
	P (Phosphorous)	4	4	3	5	5
	Zn (Zinc)	3	3	3	4	3



- Based on pre-set limits
  - OEM-set
  - Standardised
  - Statistical
  - Algorithmic
- Often accompanied by actionable comments
  - Auto-generated
  - Might be manually reviewed
- Useful for “quick glance”
- Sufficient for non-critical assets

Overall Report Status = NORMAL						
Sample Info	Report Status	Caution	Normal	Normal	Alert	Normal
	Sample ID	156989048	156989060	156989101	156989206	156989348
	Bottle ID	s989048	s89060	s989101	s89206	s989348
	Lubricant	XYZ	XYZ	XYZ	XYZ	XYZ
	Sample Date	09-08-19	09-09-19	09-10-19	09-12-19	09-01-20
	Report Date	19-08-19	19-09-19	19-10-19	19-12-19	19-01-20
	Equipment Age	54206	54300	54758	54862	55001
	Equipment UOM	Hours	Hours	Hours	Hours	Hours
	Oil Changed	Yes	No	No	Yes	No
	Oil Age	486	97	299	525	141
	Oil UOM	Hours	Hours	Hours	Hours	Hours
	Make Up Volume				160	
	Volume UOM				Litres	
	Filter Changed	Yes	No	No	Yes	No
Lubricant	Contamination Rating	Caution	Normal	Normal	Alert	Normal
	Equipment Rating	Normal	Normal	Normal	Normal	Normal
	Oil Rating	Normal	Normal	Normal	Caution	Normal
	PQ Index	1	1	0	5	4
	SAE Grade	40	40	40	40	40
	Visc @100C	15.2	14.2	14.8	15.9	15.2
	Oxidation (Abs/cm)	9	6	8	13	8
	TAN (mg KOH/g)	2.39	1.66	2.31	3.02	2.25
	Nitration (Abs/cm)	1	1	1	3	3
	TBN (mg KOH/g)	8.3	9.0	8.4	7.7	8.5
	Soot (wt%)	0.13	0.11	0.15	0.19	0.19
	Water (vol%)	Not Detected	Not Detected	Not Detected	Not Detected	Not Detected
	Coolant Indicator	Not Detected	Not Detected	Not Detected	Not Detected	Not Detected
	Cl (Cl ppm - Xray)	104	50	85	104	47
Wear (ppm)	Ag (Silver)	0	0	0	0	0
	Al (Aluminium)	3	2	2	4	2
	Cr (Chromium)	0	0	0	1	0
	Cu (Copper)	2	1	1	2	1
	Fe (Iron)	7	4	4	10	7
	Mo (Molybdenum)	4	4	3	0	1
	Ni (Nickel)	1	1	1	2	1
	Pb (Lead)	2	0	1	4	0
	Sn (Tin)	2	0	1	2	1
Ti (Titanium)	0	0	0	0	0	
Contaminant (ppm)	K (Potassium)	0	0	0	0	0
	Na (Sodium)	4	4	4	8	7
	Si (Silicon)	177	76	112	248	81
Additive (ppm)	B (Boron)	1	0	0	1	0
	Ba (Barium)	0	0	0	0	0
	Ca (Calcium)	4085	3914	3790	4379	3767
	Mg (Magnesium)	11	11	11	13	11
	P (Phosphorous)	4	4	3	5	5
	Zn (Zinc)	3	3	3	4	3

# Lvl 2: Interpretation

# Sample Information

Overall Report Status = NORMAL						
Report Status	Caution	Normal	Normal	Alert	Normal	
Sample ID	156989048	156989060	156989101	156989206	156989348	
Bottle ID	s989048	s89060	s989101	s89206	s989348	
Lubricant	XYZ	XYZ	XYZ	XYZ	XYZ	
Sample Date	09-08-19	09-09-19	09-10-19	09-12-19	09-01-20	
Report Date	19-08-19	19-09-19	19-10-19	19-12-19	19-01-20	
Equipment Age	54206	54300	54758	54862	55001	
Equipment UOM	Hours	Hours	Hours	Hours	Hours	
Oil Changed	Yes	No	No	Yes	No	
Oil Age	486	97	299	525	141	
Oil UOM	Hours	Hours	Hours	Hours	Hours	
Make Up Volume				160		
Volume UOM				Litres		
Filter Changed	Yes	No	No	Yes	No	

Fluid Condition

# Oil Parameters

Contamination Rating	Caution	Normal	Normal	Alert	Normal
Equipment Rating	Normal	Normal	Normal	Normal	Normal
Oil Rating	Normal	Normal	Normal	Caution	Normal
PQ Index	1	1	0	5	4
SAE Grade	40	40	40	40	40
Visc @100C	15.2	14.2	14.8	15.9	15.2
Oxidation (Abs/cm)	9	6	8	13	8
TAN (mg KOH/g)	2.39	1.66	2.31	3.02	2.25
Nitration (Abs/cm)	1	1	1	3	3
TBN (mg KOH/g)	8.3	9.0	8.4	7.7	8.5
Soot (wt%)	0.13	0.11	0.15	0.19	0.19
Water (vol%)	Not Detected	Not Detected	Not Detected	Not Detected	Not Detected
Coolant Indicator	Not Detected	Not Detected	Not Detected	Not Detected	Not Detected
Cl (Cl ppm - Xray)	104	50	85	104	47

Wear Information

# Wear

Ag (Silver)	0	0	0	0	0
Al (Aluminium)	3	2	2	4	2
Cr (Chromium)	0	0	0	1	0
Cu (Copper)	2	1	1	2	1
Fe (Iron)	7	4	4	10	7
Mo (Molybdenum)	4	4	3	0	1
Ni (Nickel)	1	1	1	2	1
Pb (Lead)	2	0	1	4	0
Sn (Tin)	2	0	1	2	1
Ti (Titanium)	0	0	0	0	0

Contamination

# Contaminants

K (Potassium)	0	0	0	0	0
Na (Sodium)	4	4	4	8	7
Si (Silicon)	177	76	112	248	81

Fluid Condition

# Additives

B (Boron)	1	0	0	1	0
Ba (Barium)	0	0	0	0	0
Ca (Calcium)	4085	3914	3790	4379	3767
Mg (Magnesium)	11	11	11	13	11
P (Phosphorous)	4	4	3	5	5
Zn (Zinc)	3	3	3	4	3

Metal	Symbol	Possible Sources
Iron	Fe	Engine components, rust, contamination
Chromium	Cr	Piston rings, valves, anti-wear additives
Aluminum	Al	Pistons, bearings, housings, contamination
Copper	Cu	Bearings, bushings, oil coolers, anti-wear additives
Lead	Pb	Bearings, bushings, fuel additives, contamination
Tin	Sn	Bearings, bushings, solder
Nickel	Ni	Valves, turbine blades, contamination
Silver	Ag	Bearings, bushings, electrical contacts
Titanium	Ti	Engine components, turbine blades, contamination
Molybdenum	Mo	Anti-wear additives, piston rings, contamination
Silicon	Si	Dirt, sand, gasket materials, anti-foaming additives
Sodium	Na	Antifreeze, coolant, saltwater contamination, detergent additives
Potassium	K	Antifreeze, coolant, contamination
Calcium	Ca	Detergent and dispersant additives
Magnesium	Mg	Detergent and dispersant additives
Phosphorus	P	Anti-wear and extreme pressure additives
Zinc	Zn	Anti-wear and extreme pressure additives

Shell Mysella S5N has been tested after 300 hours of use in a Jenbacher J320 running on natural gas. The laboratory is showing a “caution” alarm.

TAN = 1.0, TBN = 4.0, Oxidation = 18

What is missing from this analysis?

Shell Mysella S5N has been tested after 300 hours of use in a Jenbacher J320 running on natural gas. The laboratory is showing a “caution” alarm.

TAN = 1.0, TBN = 4.0, Oxidation = 18

What is missing from this analysis? [Test method information](#)

Mobil Jet Oil II tested at a local laboratory. The report shows an “alert” alarm for phenolic antioxidants, the recommendation is to change the oil.

Phenols 15%, Amines 95%

What is missing from this analysis?

Mobil Jet Oil II tested at a local laboratory. The report shows an “alert” alarm for phenolic antioxidants, the recommendation is to change the oil.

Phenols 15%, Amines 95%

What is missing from this analysis? [Formulation information](#)



Caltex Delo Gold Ultra tested at a local laboratory. The report shows an “alert” alarm for copper, the recommendation is to check the crankcase bearings for damage.

Copper = 80 ppm, Tin = 2 ppm, Lead = 0 ppm

What is missing from this analysis?

Caltex Delo Gold Ultra tested at a local laboratory. The report shows an “alert” alarm for copper, the recommendation is to check the crankcase bearings for damage.

Copper = 80 ppm, Tin = 2 ppm, Lead = 0 ppm

What is missing from this analysis? [Operational information](#)

Steel backing

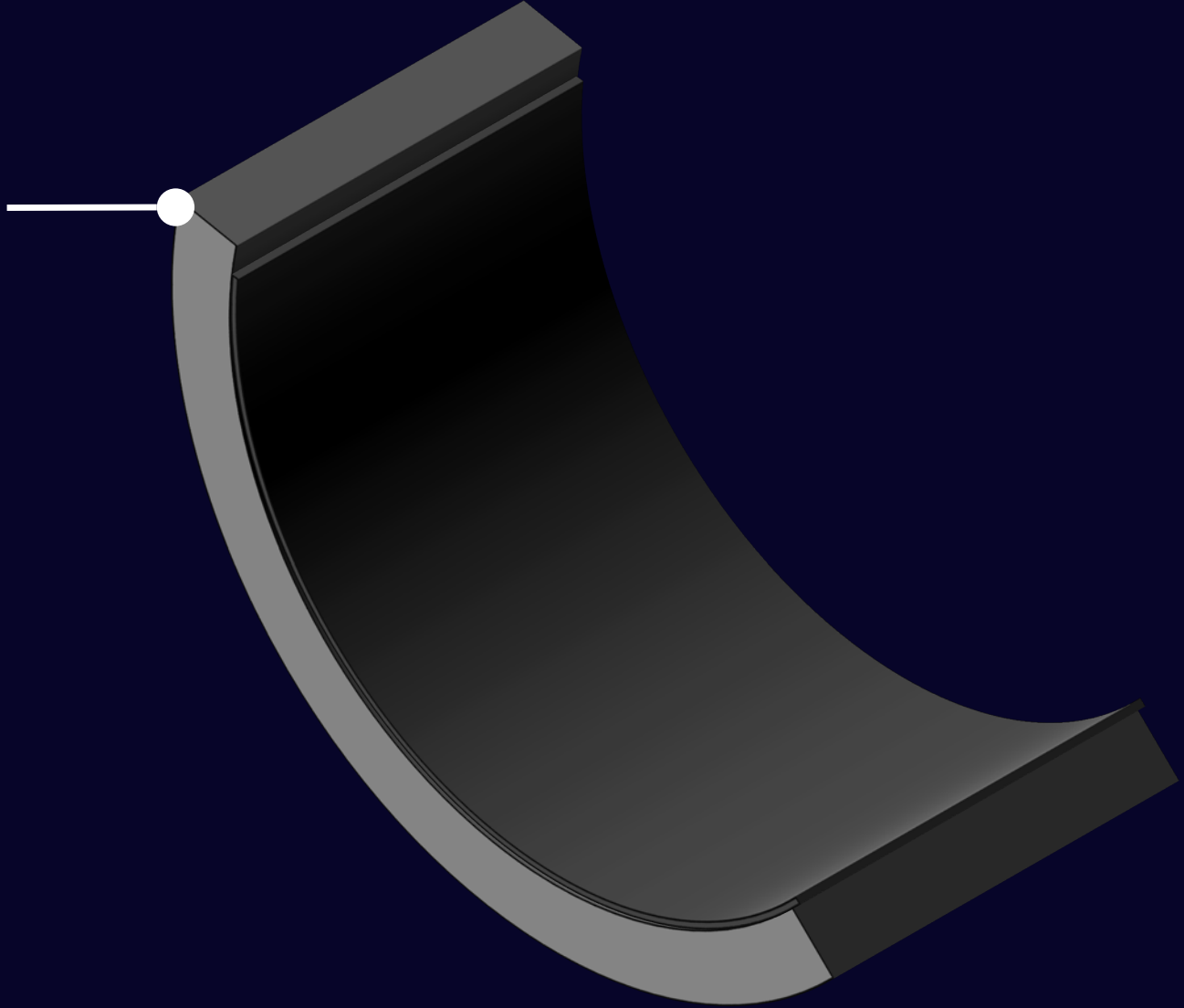

Copper Alloy

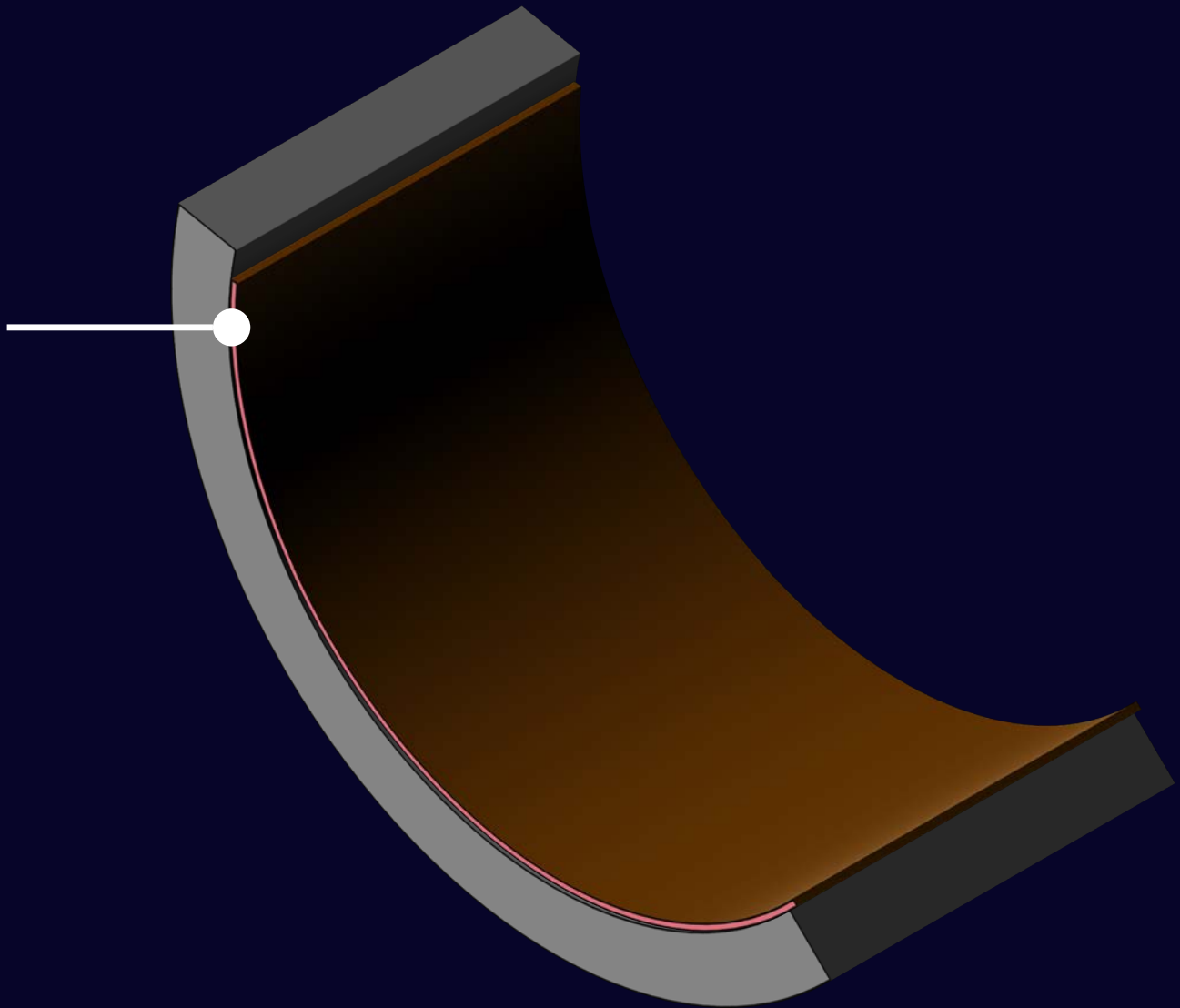

Nickel Barrier

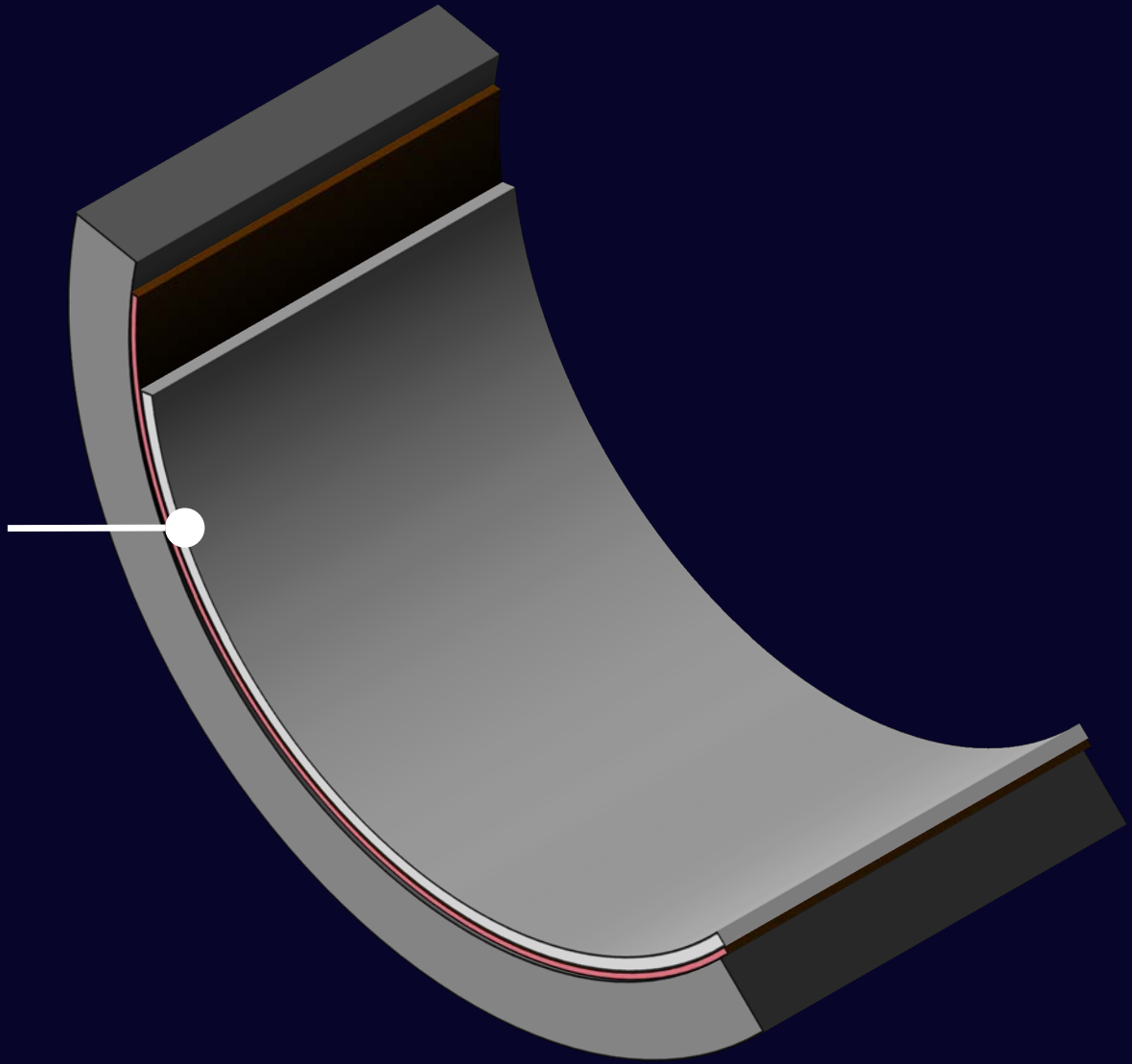

Bearing overlay

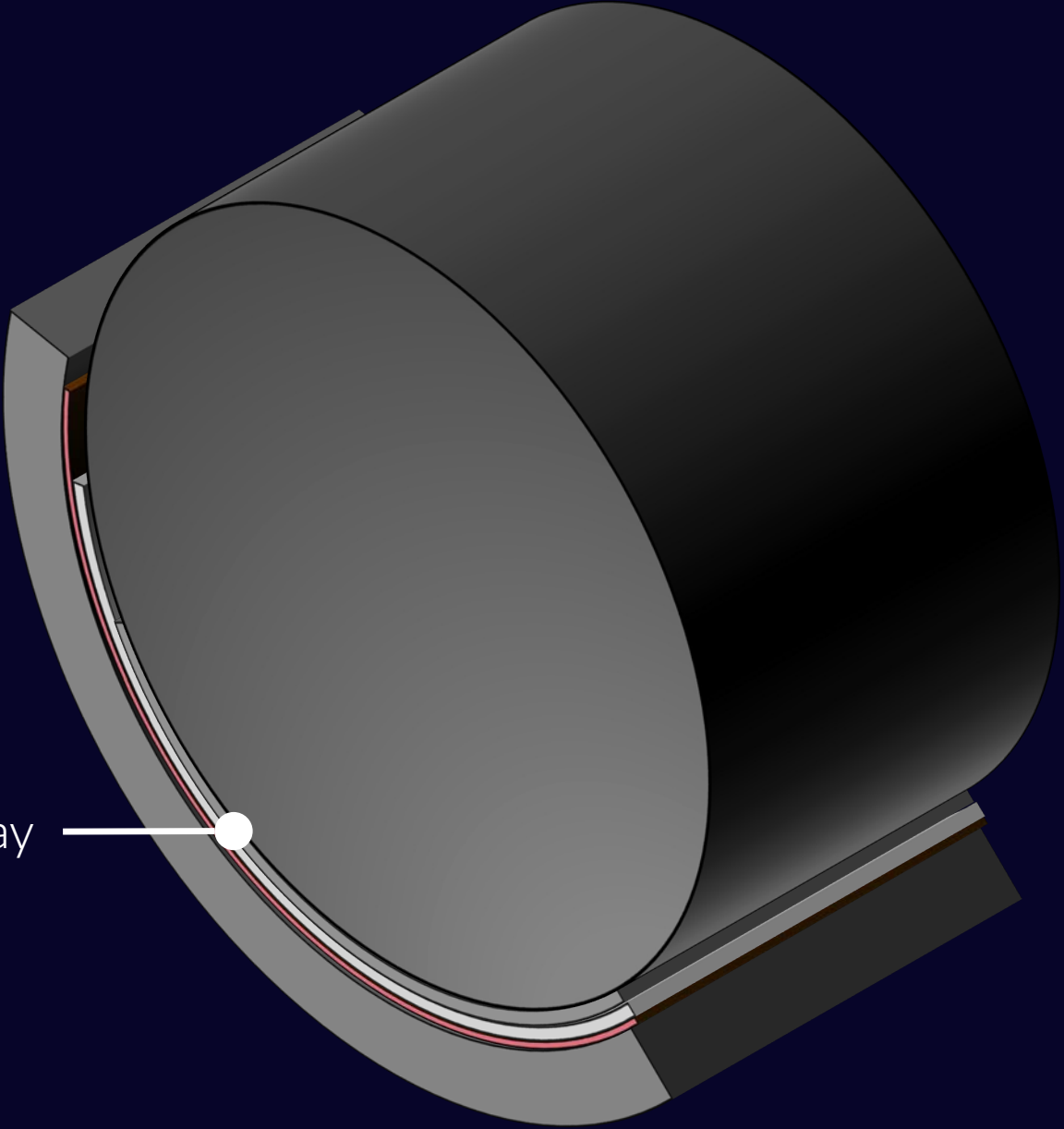

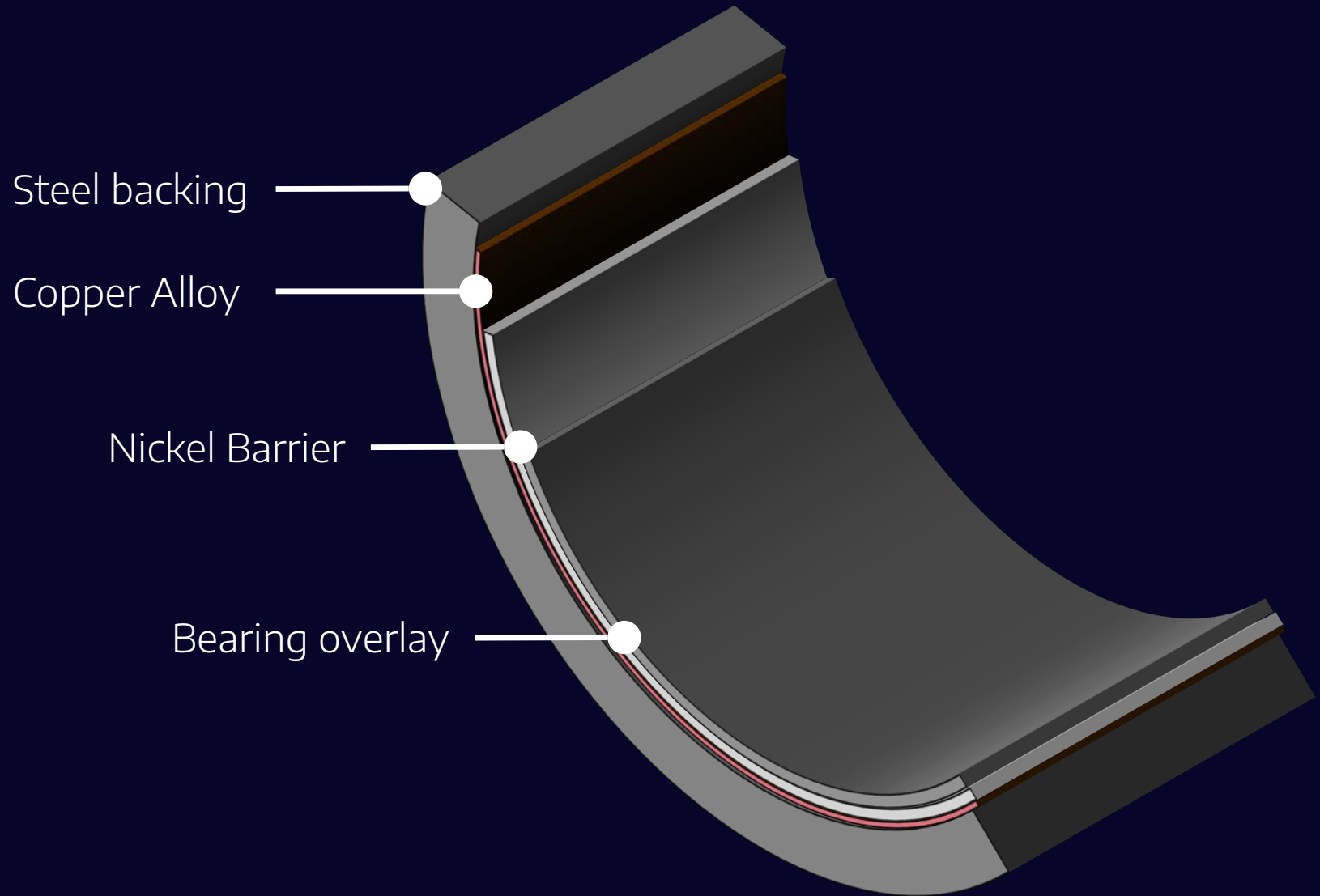

Test Method  
Formulation  
Ops / maintenance



# Lvl 3: Trend Analysis

# Copper vs Oil Hours

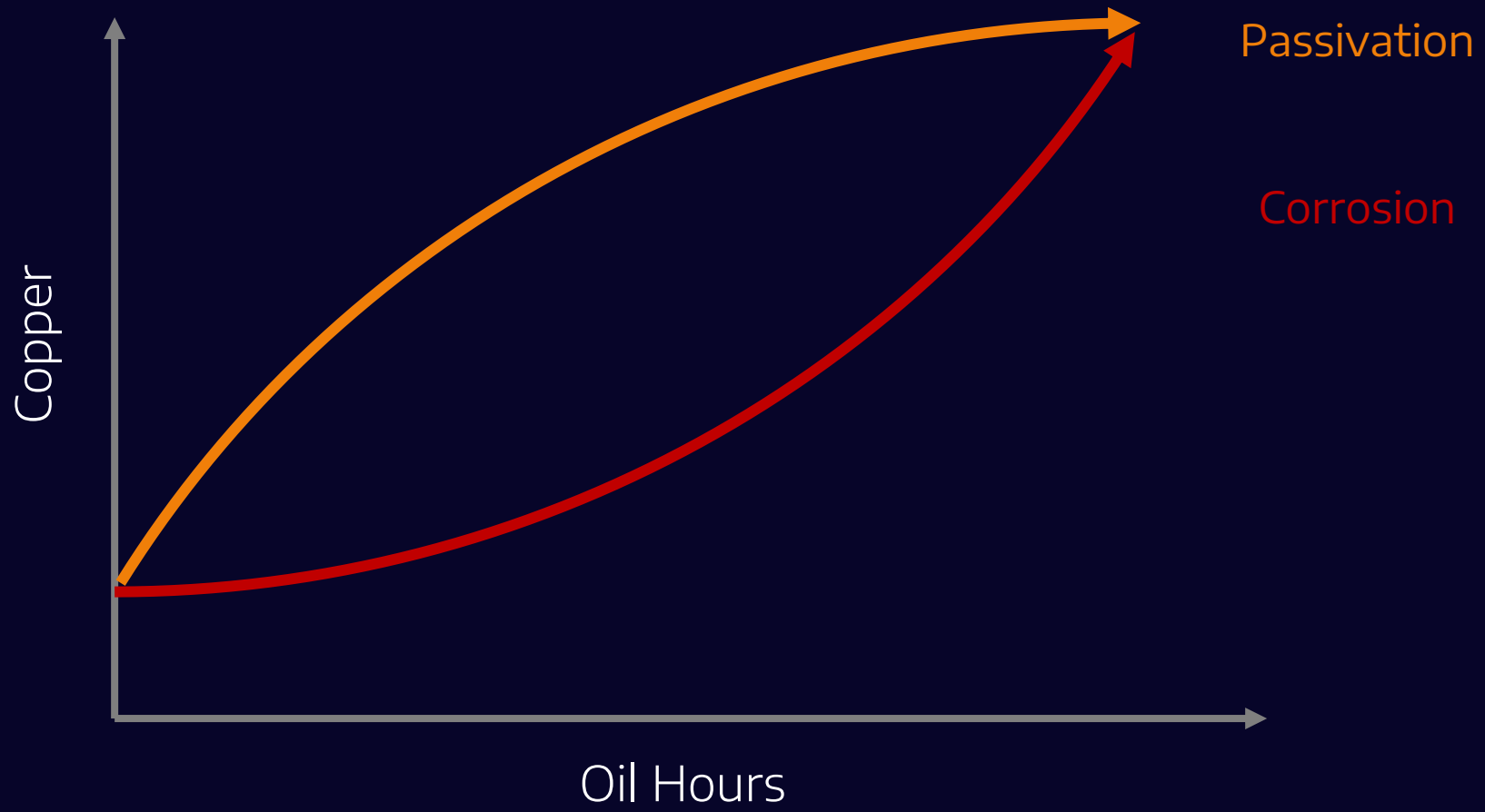

## Sample Information

Overall Report Status = NORMAL						
Sample Info	Report Status	Caution	Normal	Normal	Alert	Normal
	Sample ID	156989048	156989060	156989101	156989206	156989348
	Bottle ID	s989048	s89060	s989101	s89206	s989348
	Lubricant	XYZ	XYZ	XYZ	XYZ	XYZ
	Sample Date	09-08-19	09-09-19	09-10-19	09-12-19	09-01-20
	Report Date	19-08-19	19-09-19	19-10-19	19-12-19	19-01-20
	Equipment Age	54206	54300	54758	54862	55001
	Equipment UOM	Hours	Hours	Hours	Hours	Hours
	Oil Changed	Yes	No	No	Yes	No
	Oil Age	486	97	299	525	141
	Oil UOM	Hours	Hours	Hours	Hours	Hours
	Make Up Volume				160	
	Volume UOM				Litres	
	Filter Changed	Yes	No	No	Yes	No
Lubricant	Contamination Rating	Caution	Normal	Normal	Alert	Normal
	Equipment Rating	Normal	Normal	Normal	Normal	Normal
	Oil Rating	Normal	Normal	Normal	Caution	Normal
	PQ Index	1	1	0	5	4
	SAE Grade	40	40	40	40	40
	Visc @100C	15.2	14.2	14.8	15.9	15.2
	Oxidation (Abs/cm)	9	6	8	13	8
	TAN (mg KOH/g)	2.39	1.66	2.31	3.02	2.25
	Nitration (Abs/cm)	1	1	1	3	3
	TBN (mg KOH/g)	8.3	9.0	8.4	7.7	8.5
	Soot (wt%)	0.13	0.11	0.15	0.19	0.19
	Water (vol%)	Not Detected	Not Detected	Not Detected	Not Detected	Not Detected
	Coolant Indicator	Not Detected	Not Detected	Not Detected	Not Detected	Not Detected
	Cl (Cl ppm - Xray)	104	50	85	104	47
Wear (ppm)	Ag (Silver)	0	0	0	0	0
	Al (Aluminium)	3	2	2	4	2
	Cr (Chromium)	0	0	0	1	0
	Cu (Copper)	2	1	1	2	1
	Fe (Iron)	7	4	4	10	7
	Mo (Molybdenum)	4	4	3	0	1
	Ni (Nickel)	1	1	1	2	1
	Pb (Lead)	2	0	1	4	0
	Sn (Tin)	2	0	1	2	1
Ti (Titanium)	0	0	0	0	0	
Contaminant (ppm)	K (Potassium)	0	0	0	0	0
	Na (Sodium)	4	4	4	8	7
	Si (Silicon)	177	76	112	248	81
Additive (ppm)	B (Boron)	1	0	0	1	0
	Ba (Barium)	0	0	0	0	0
	Ca (Calcium)	4085	3914	3790	4379	3767
	Mg (Magnesium)	11	11	11	13	11
	P (Phosphorous)	4	4	3	5	5
	Zn (Zinc)	3	3	3	4	3

Fluid Condition

Wear Information

Contamination

Fluid Condition

## Oil Parameters

## Wear

## Contaminants

## Additives

# Sample Information

Fluid Condition

Oil Parameters

Wear Information

Wear

Contamination

Contaminants

Fluid Condition

Additives

Overall Report Status = NORMAL						
Sample Info	Report Status	Caution	Normal	Normal	Alert	Normal
	Sample ID	156989048	156989060	156989101	156989206	156989348
	Bottle ID	s989048	s89060	s989101	s89206	s989348
	Lubricant	XYZ	XYZ	XYZ	XYZ	XYZ
	Sample Date	09-08-19	09-09-19	09-10-19	09-12-19	09-01-20
	Report Date	19-08-19	19-09-19	19-10-19	19-12-19	19-01-20
	Equipment Age	54206	54300	54758	54862	55001
	Equipment UOM	Hours	Hours	Hours	Hours	Hours
	Oil Changed	Yes	No	No	Yes	No
	Oil Age	486	97	299	525	141
	Oil UOM	Hours	Hours	Hours	Hours	Hours
	Make Up Volume				160	
	Volume UOM				Litres	
	Filter Changed	Yes	No	No	Yes	No
	Lubricant	Contamination Rating	Caution	Normal	Normal	Alert
Equipment Rating		Normal	Normal	Normal	Normal	Normal
Oil Rating		Normal	Normal	Normal	Caution	Normal
PQ Index		1	1	0	5	4
SAE Grade		40	40	40	40	40
Visc @100C		15.2	14.2	14.8	15.9	15.2
Oxidation (Abs/cm)		9	6	8	13	8
TAN (mg KOH/g)		2.39	1.66	2.31	3.02	2.25
Nitration (Abs/cm)		1	1	1	3	3
TBN (mg KOH/g)		8.3	9.0	8.4	7.7	8.5
Soot (wt%)		0.13	0.11	0.15	0.19	0.19
Water (vol%)		Not Detected	Not Detected	Not Detected	Not Detected	Not Detected
Coolant Indicator		Not Detected	Not Detected	Not Detected	Not Detected	Not Detected
Cl (Cl ppm - Xray)		104	50	85	104	47
Wear (ppm)		Ag (Silver)	0	0	0	0
	Al (Aluminium)	3	2	2	4	2
	Cr (Chromium)	0	0	0	1	0
	Cu (Copper)	2	1	1	2	1
	Fe (Iron)	7	4	4	10	7
	Mo (Molybdenum)	4	4	3	0	1
	Ni (Nickel)	1	1	1	2	1
	Pb (Lead)	2	0	1	4	0
	Sn (Tin)	2	0	1	2	1
	Ti (Titanium)	0	0	0	0	0
Contaminant (ppm)	K (Potassium)	0	0	0	0	0
	Na (Sodium)	4	4	4	8	7
	Si (Silicon)	177	76	112	248	81
Additive (ppm)	B (Boron)	1	0	0	1	0
	Ba (Barium)	0	0	0	0	0
	Ca (Calcium)	4085	3914	3790	4379	3767
	Mg (Magnesium)	11	11	11	13	11
	P (Phosphorous)	4	4	3	5	5
	Zn (Zinc)	3	3	3	4	3

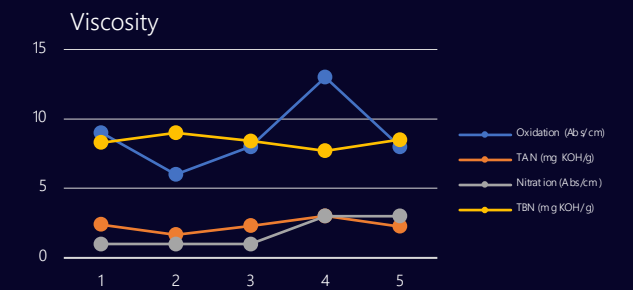
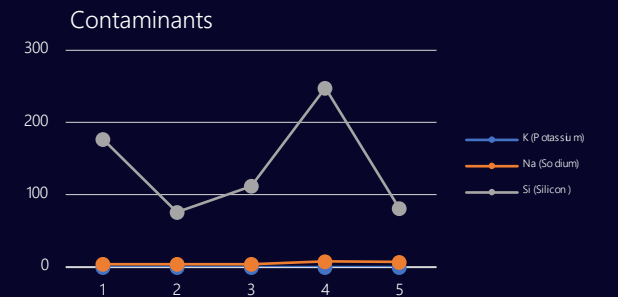
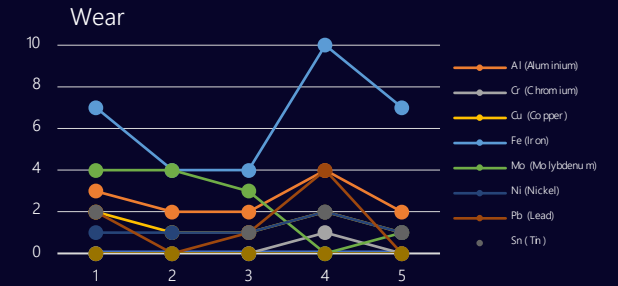
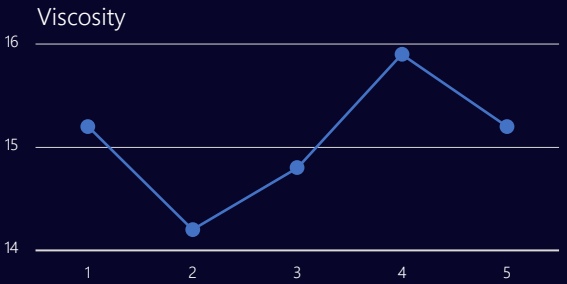

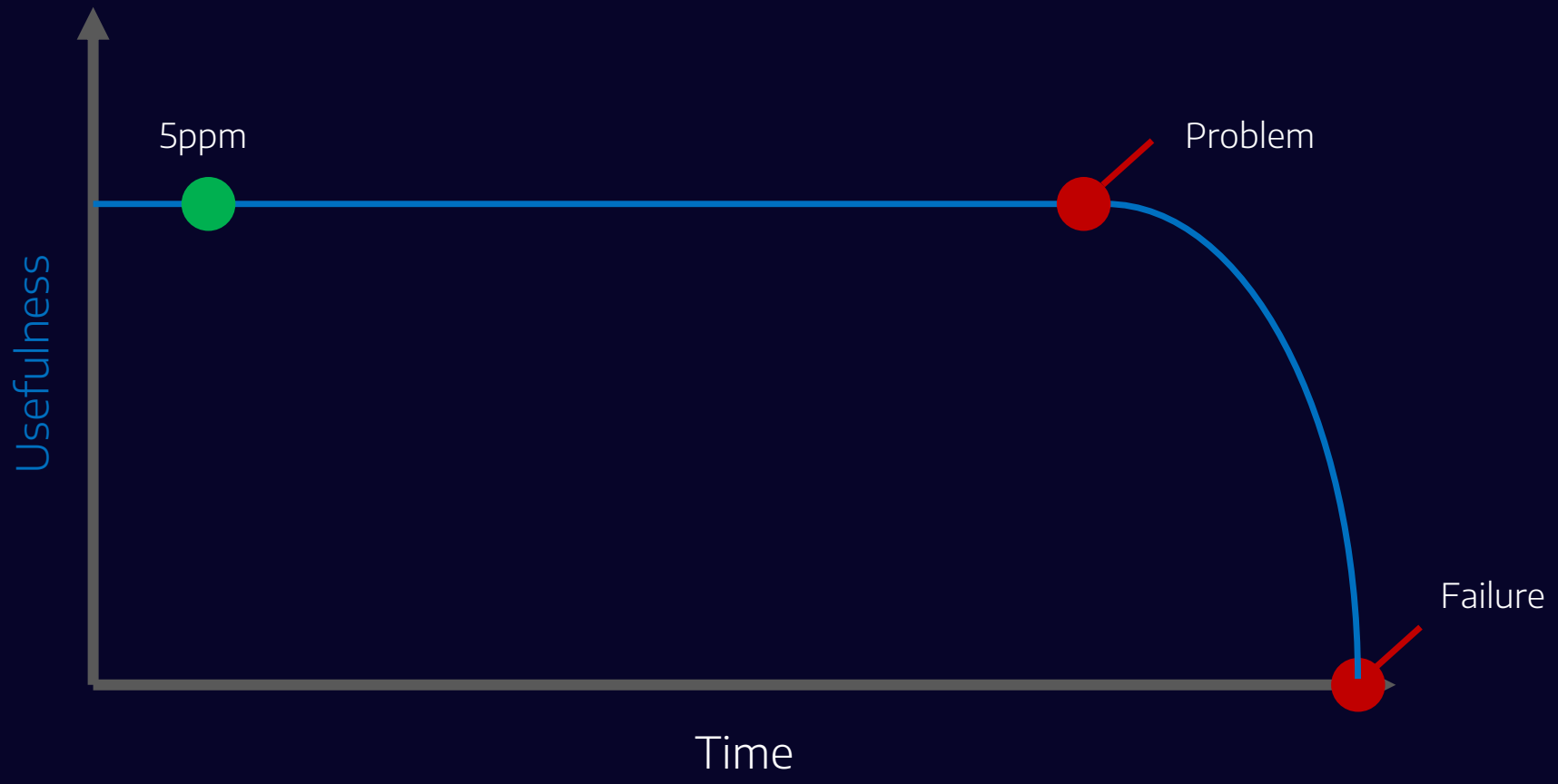

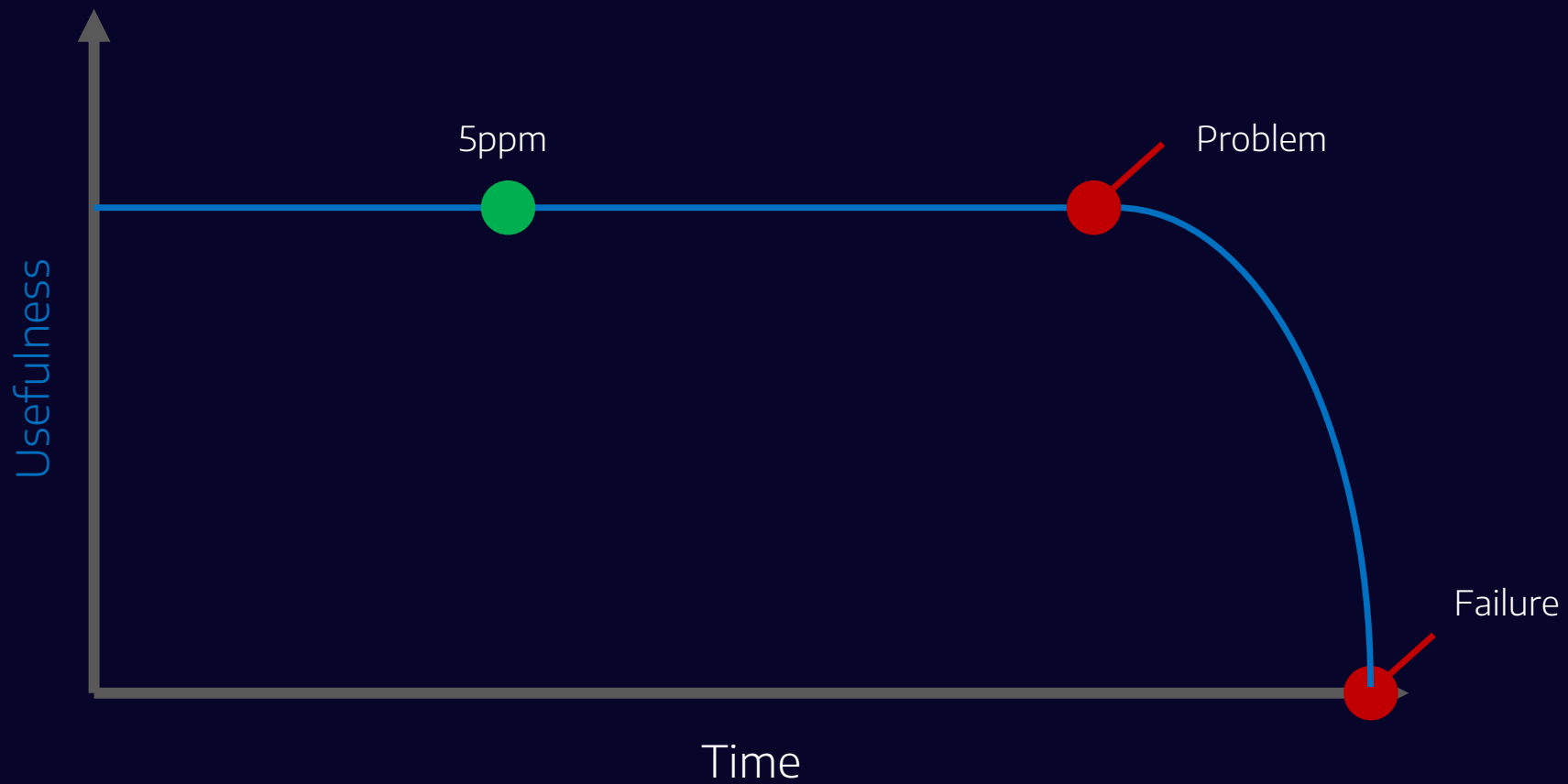

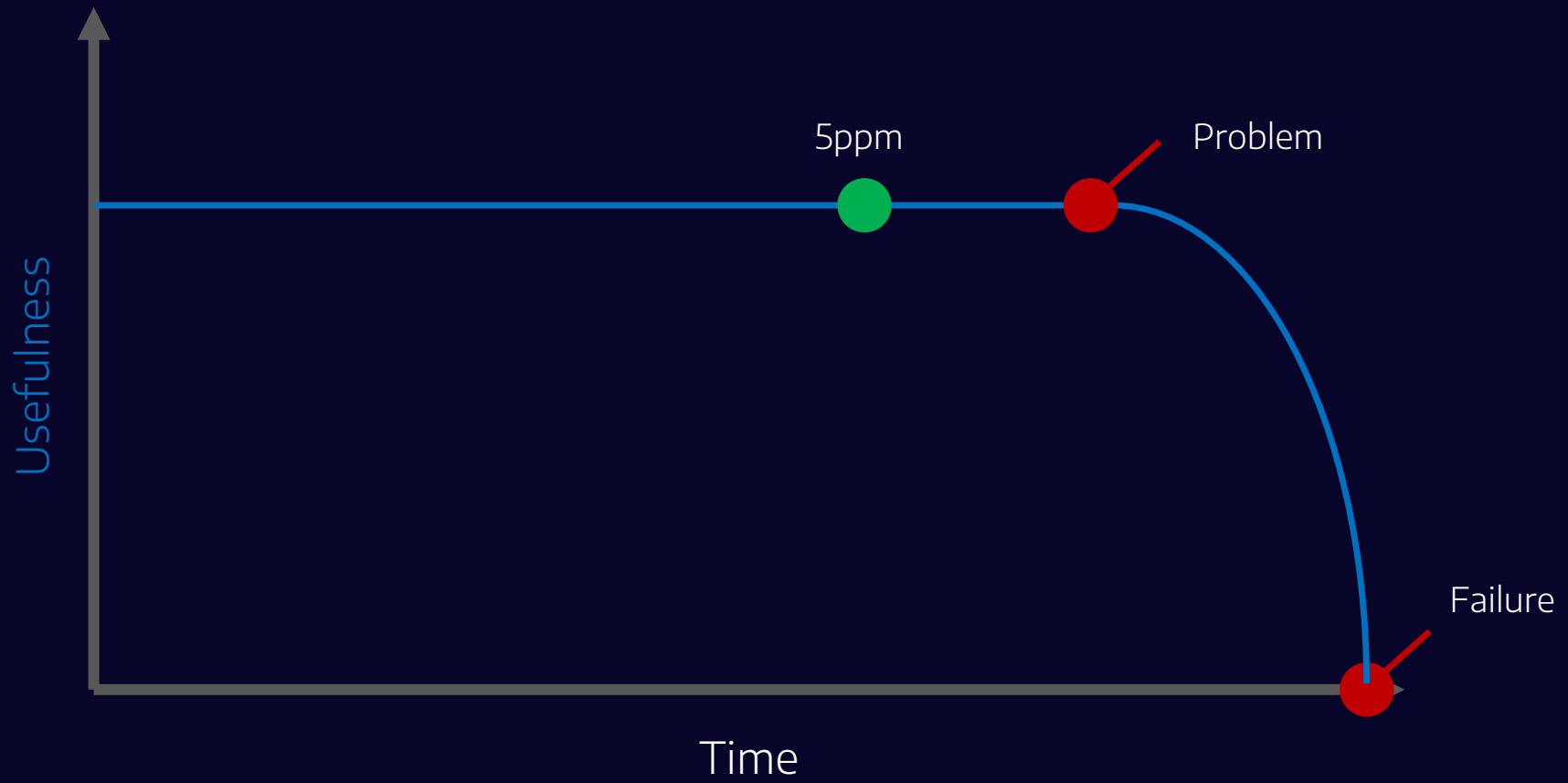

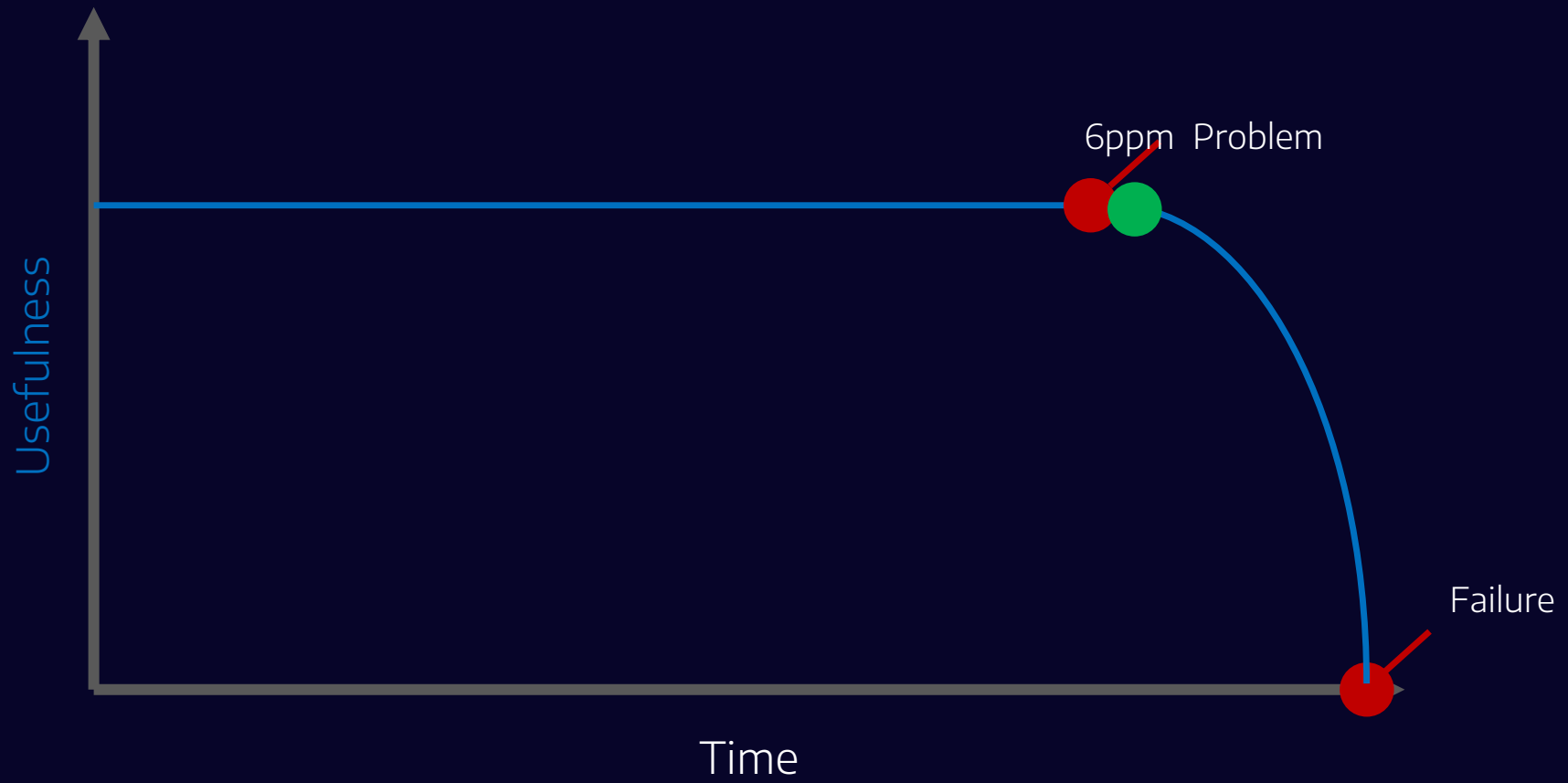



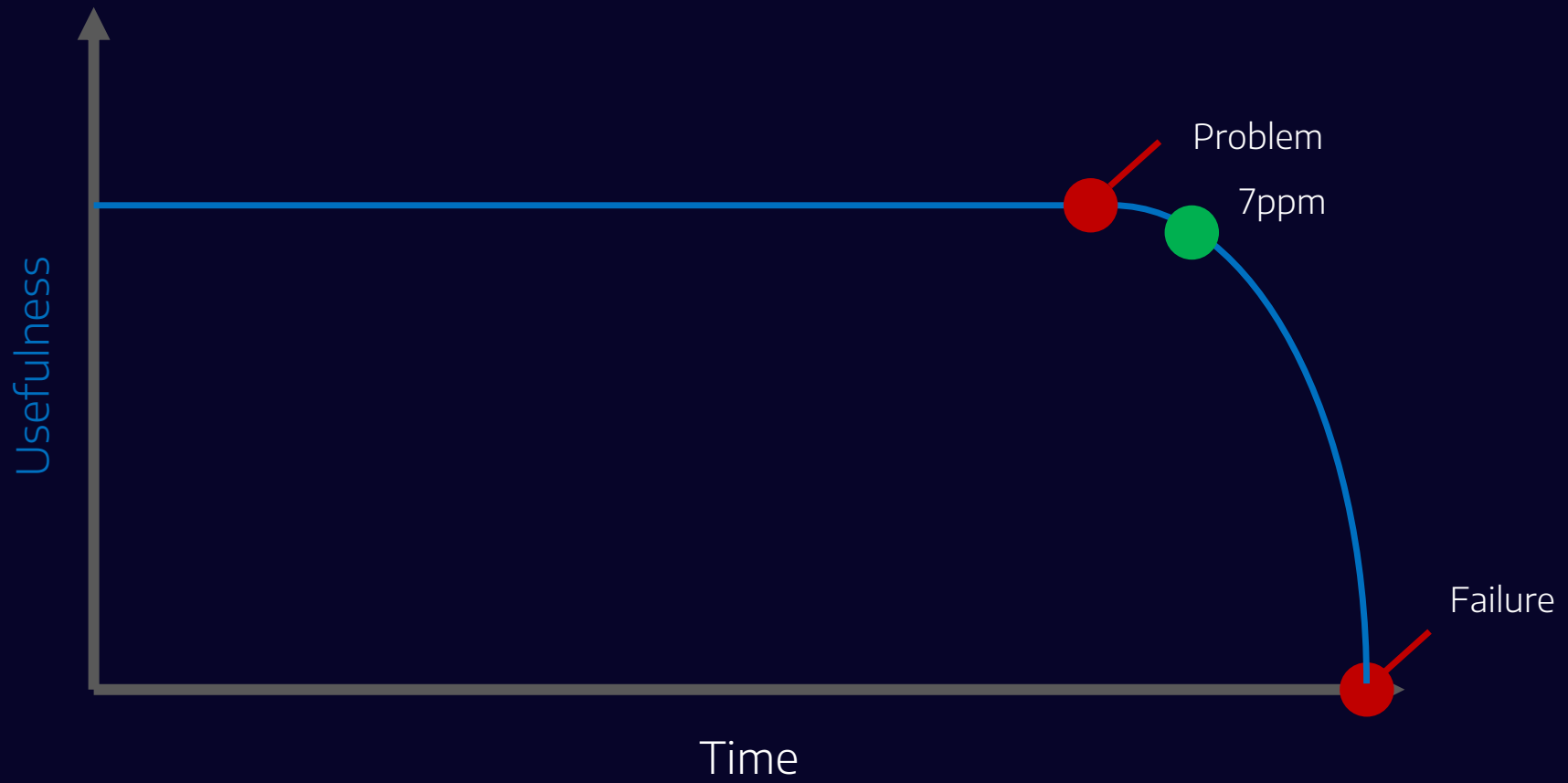

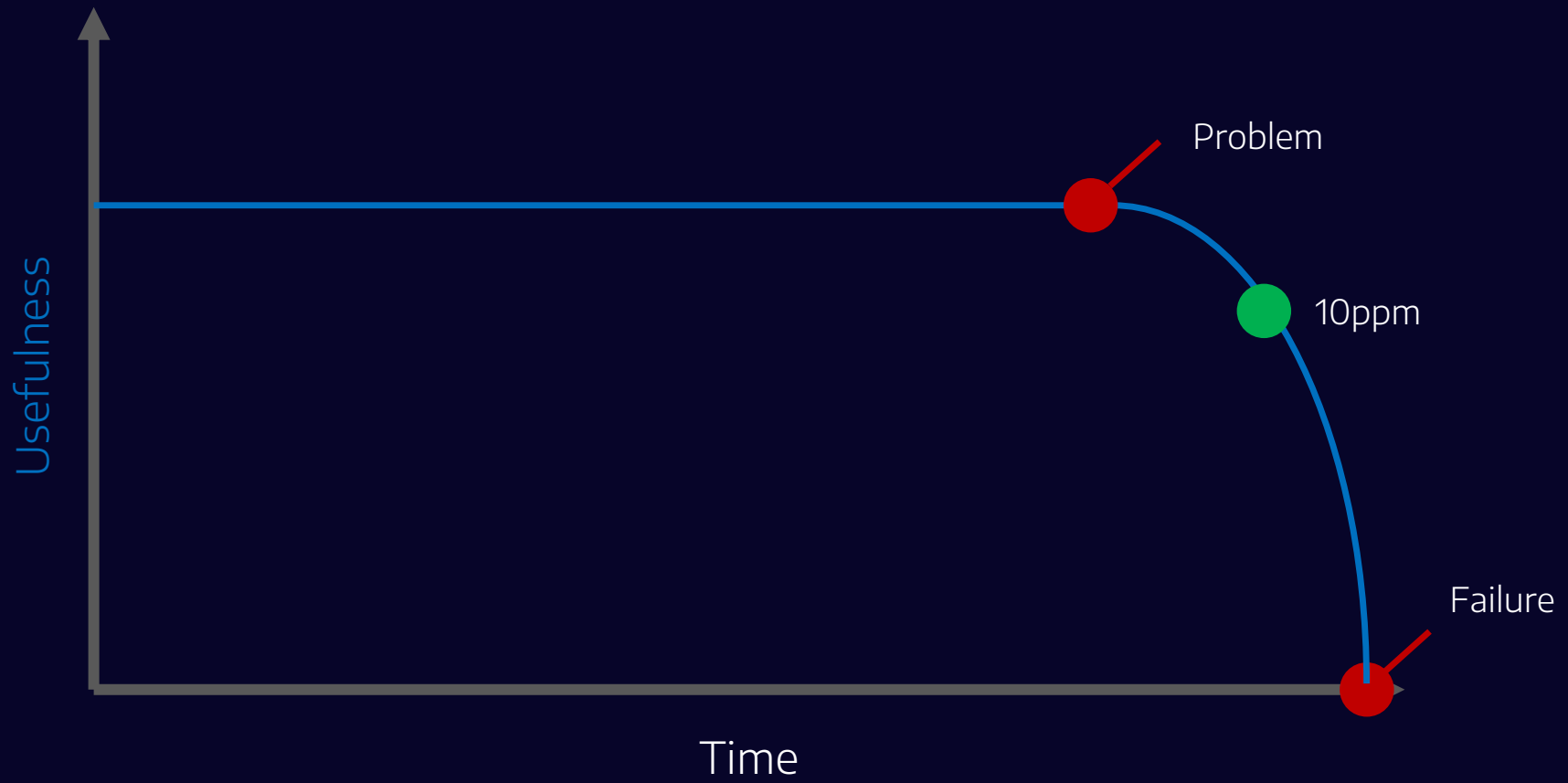

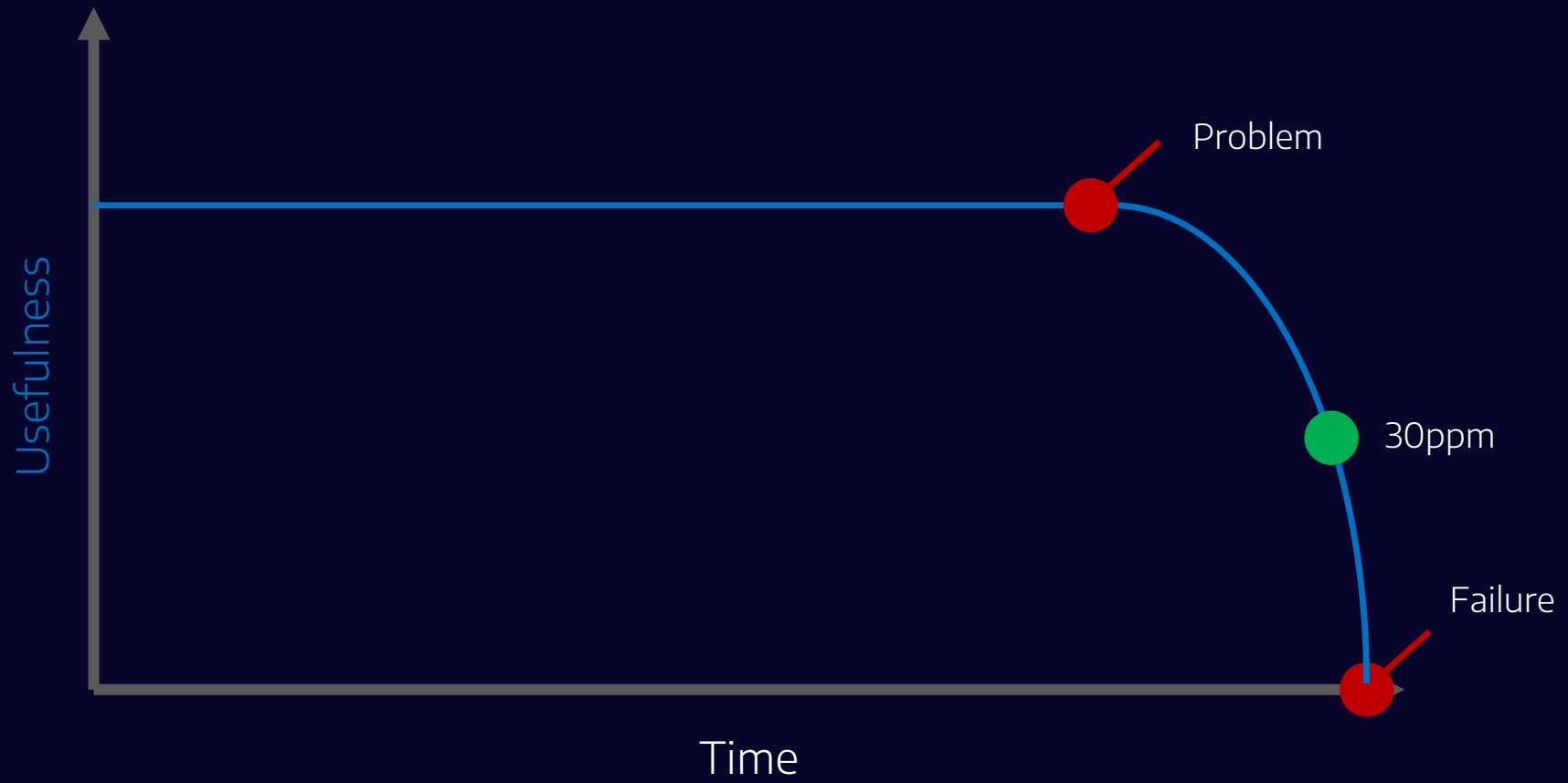

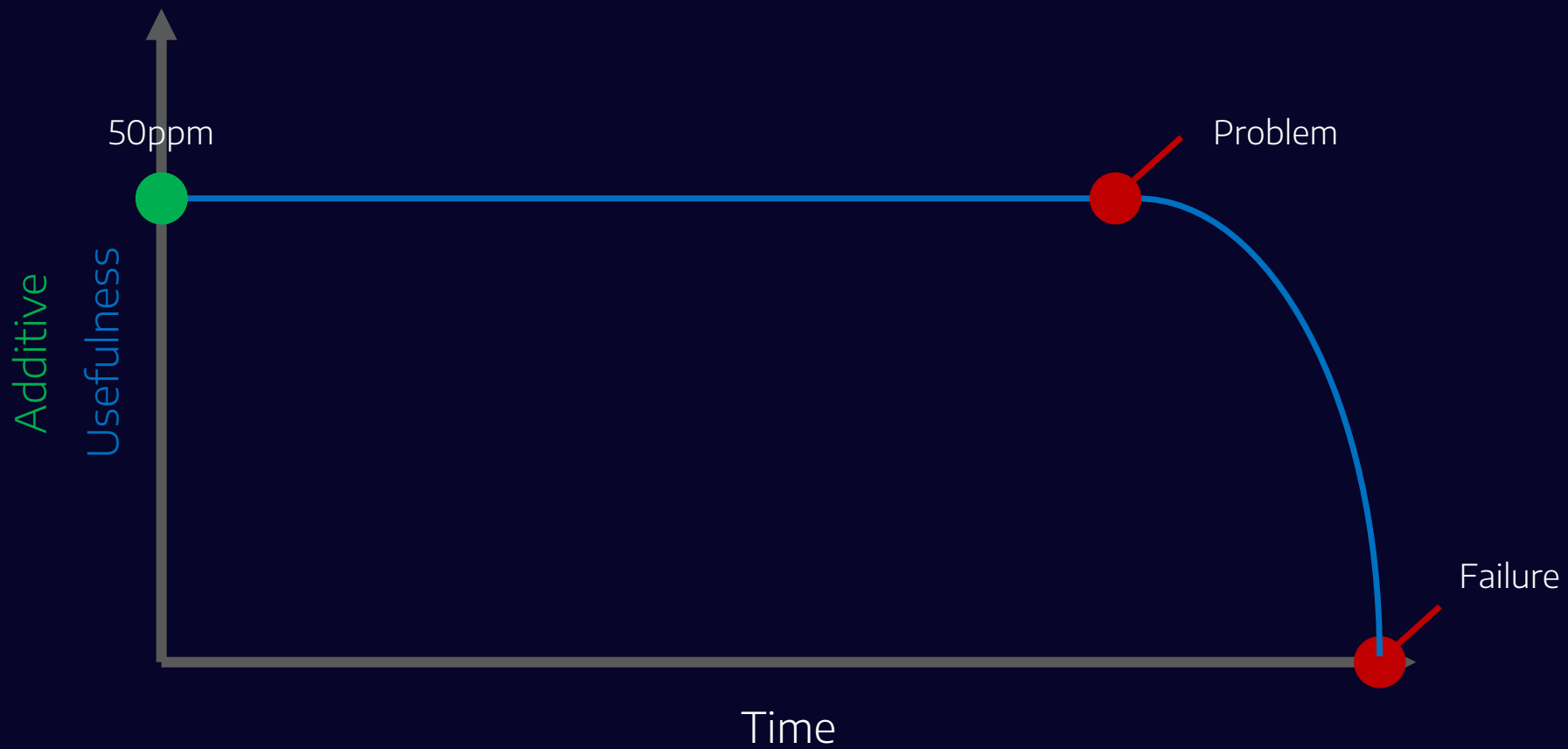

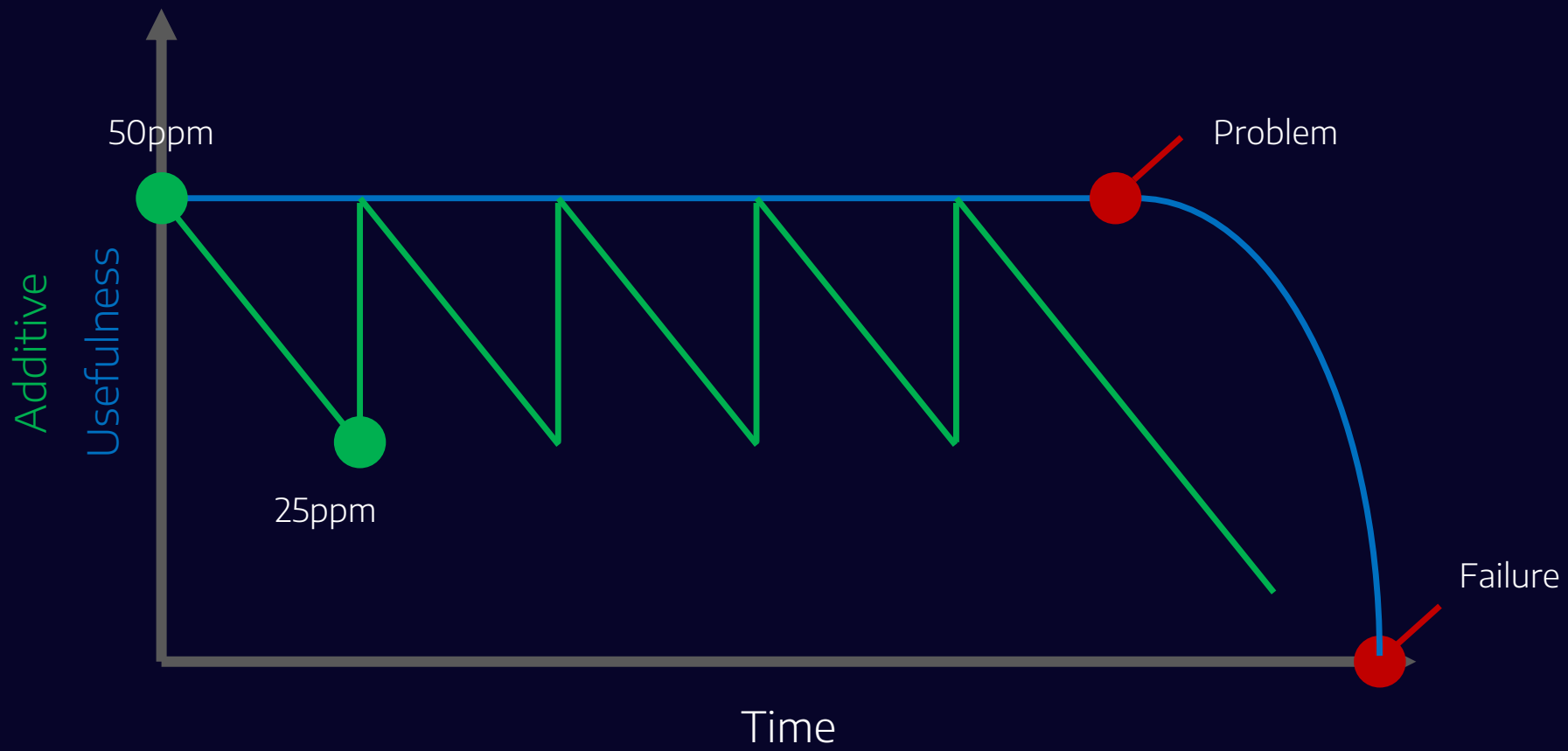

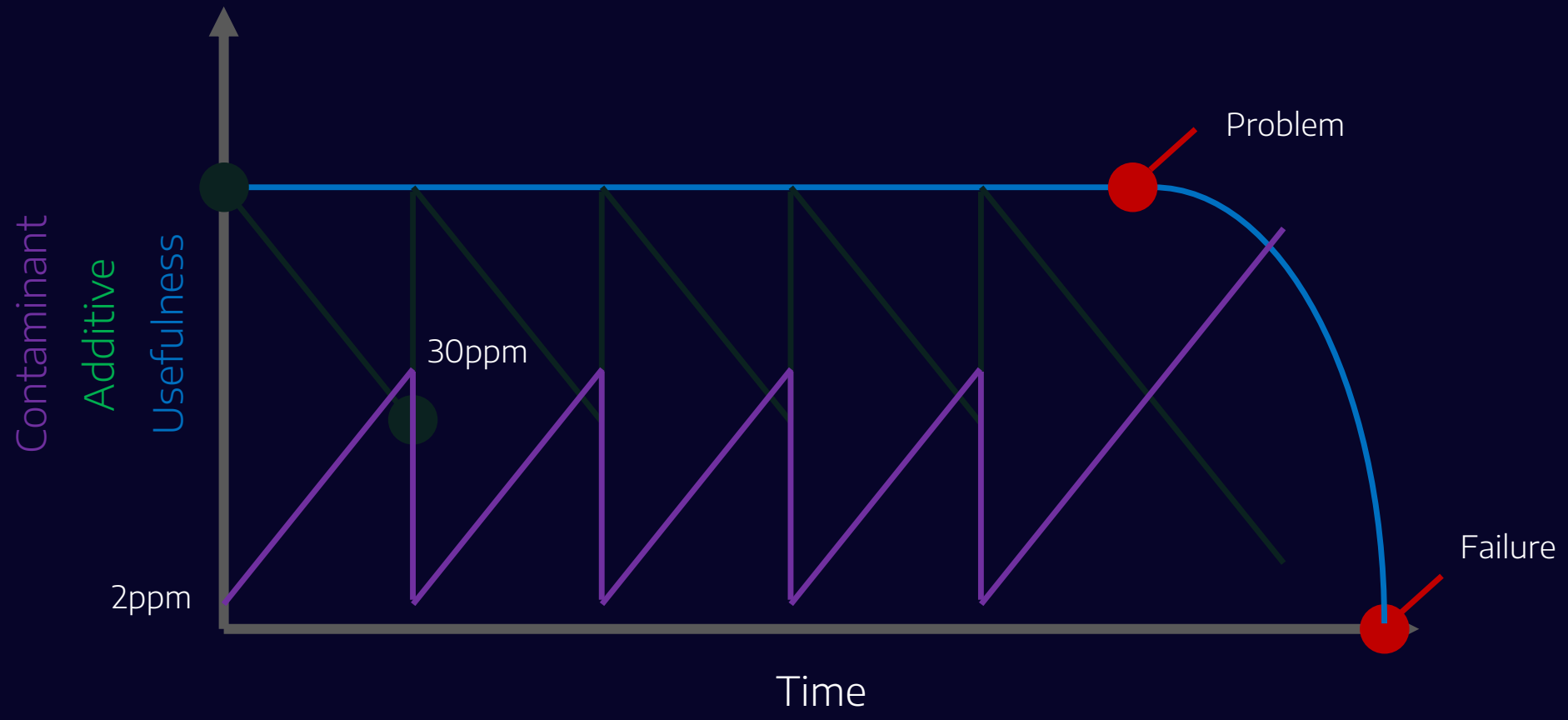

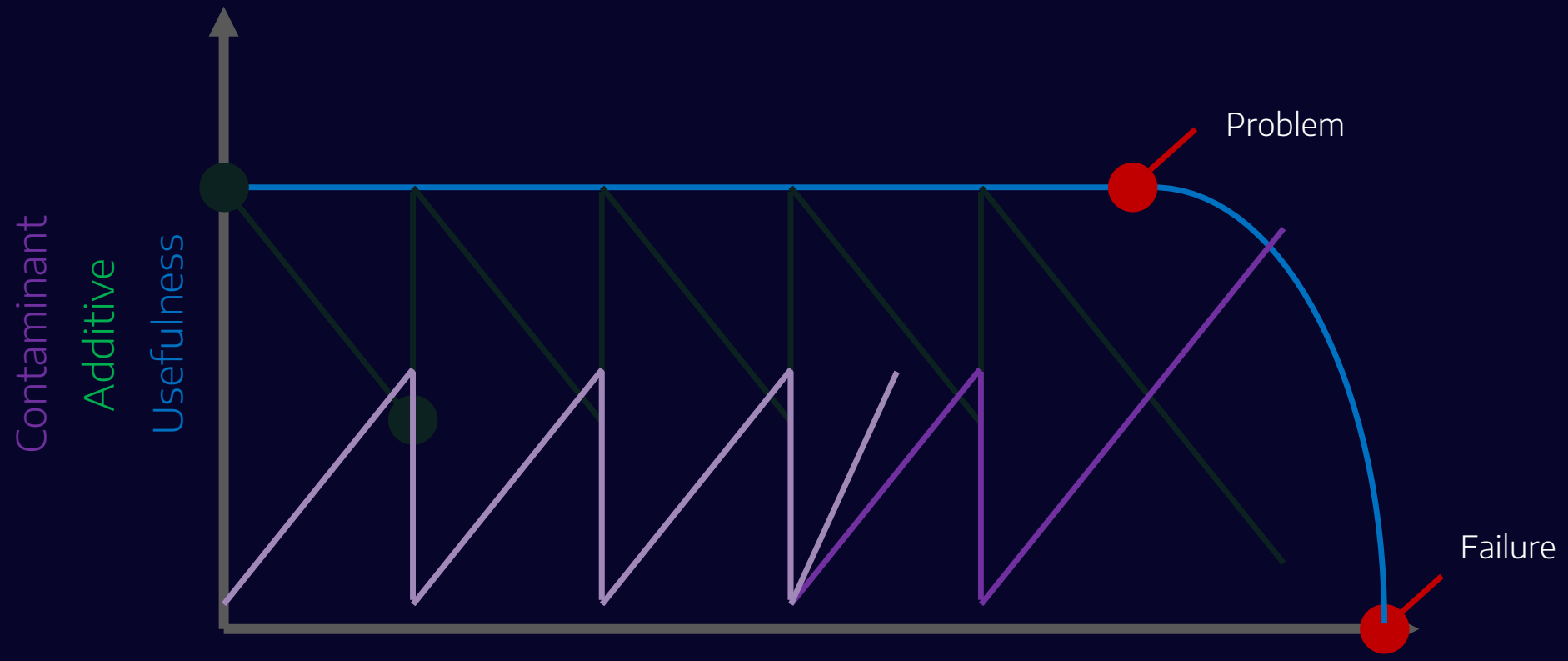

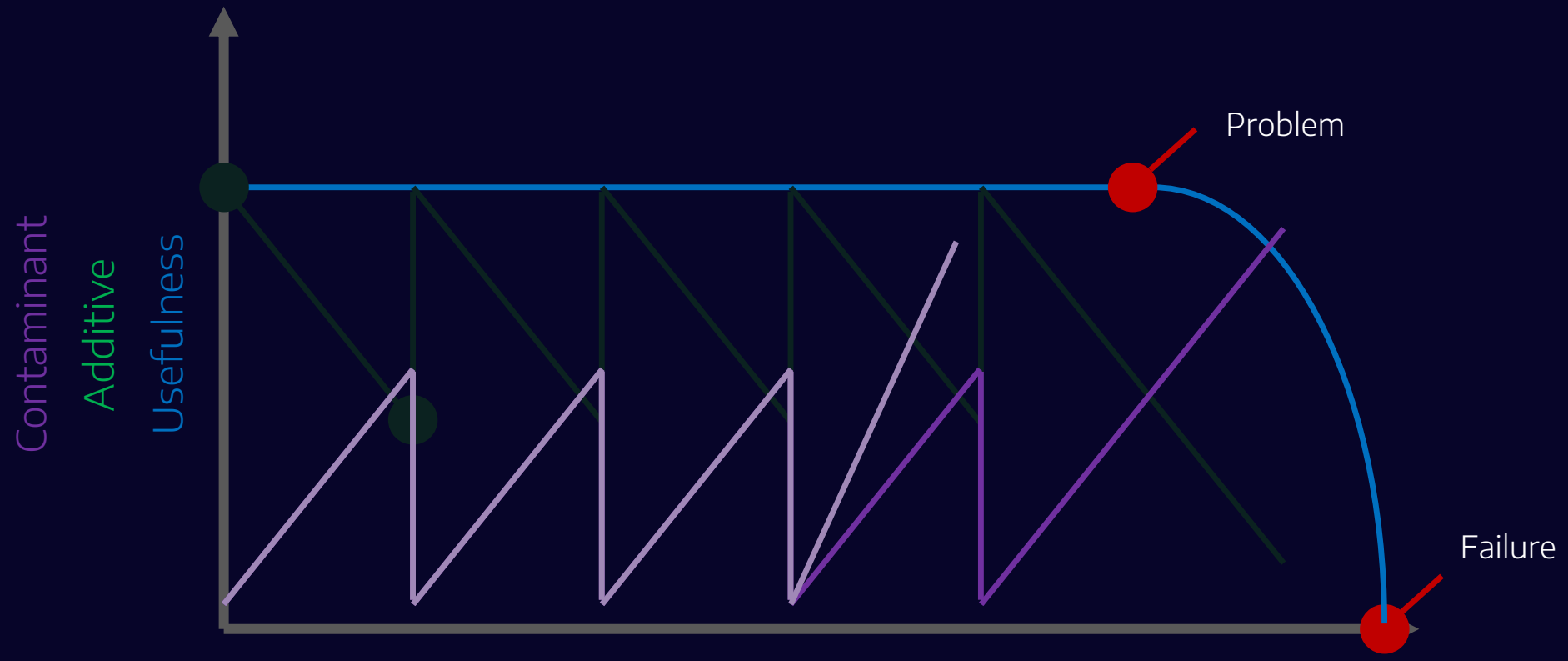



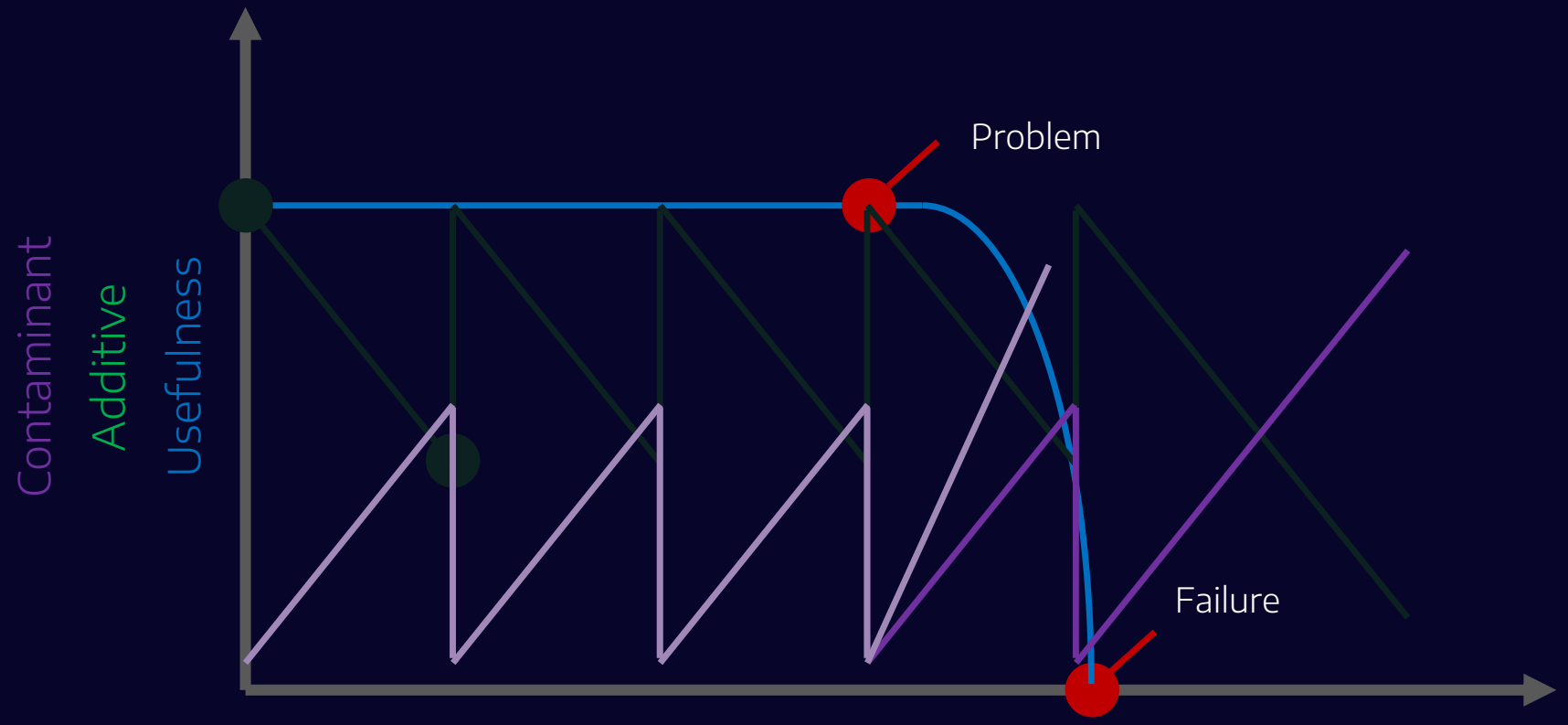

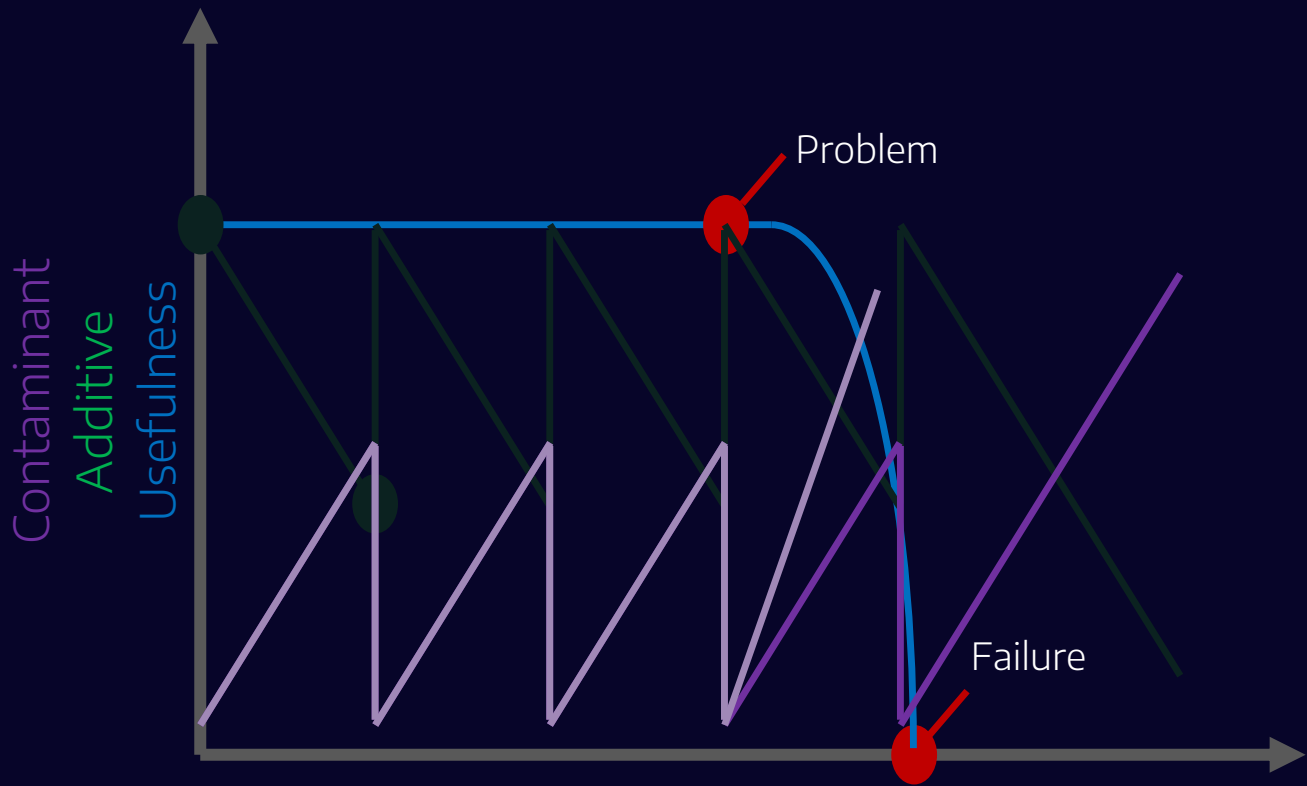

Overall Report Status = NORMAL						
Sample Info	Report Status	Caution	Normal	Normal	Alert	Normal
	Sample ID	156989048	156989060	156989101	156989206	156989348
	Bottle ID	s989048	s89060	s989101	s89206	s989348
	Lubricant	XYZ	XYZ	XYZ	XYZ	XYZ
	Sample Date	09-08-19	09-09-19	09-10-19	09-12-19	09-01-20
	Report Date	19-08-19	19-09-19	19-10-19	19-12-19	19-01-20
	Equipment Age	54206	54300	54758	54862	55001
	Equipment UOM	Hours	Hours	Hours	Hours	Hours
	Oil Changed	Yes	No	No	Yes	No
	Oil Age	486	97	299	525	141
	Oil UOM	Hours	Hours	Hours	Hours	Hours
	Make Up Volume				160	
	Volume UOM				Litres	
	Filter Changed	Yes	No	No	Yes	No
Lubricant	Contamination Rating	Caution	Normal	Normal	Alert	Normal
	Equipment Rating	Normal	Normal	Normal	Normal	Normal
	Oil Rating	Normal	Normal	Normal	Caution	Normal
	PQ Index	1	1	0	5	4
	SAE Grade	40	40	40	40	40
	Visc @100C	15.2	14.2	14.8	15.9	15.2
	Oxidation (Abs/cm)	9	6	8	13	8
	TAN (mg KOH/g)	2.39	1.66	2.31	3.02	2.25
	Nitration (Abs/cm)	1	1	1	3	3
	TBN (mg KOH/g)	8.3	9.0	8.4	7.7	8.5
	Soot (wt%)	0.13	0.11	0.15	0.19	0.19
	Water (vol%)	Not Detected	Not Detected	Not Detected	Not Detected	Not Detected
	Coolant Indicator	Not Detected	Not Detected	Not Detected	Not Detected	Not Detected
	Cl (Cl ppm - Xray)	104	50	85	104	47
Wear (ppm)	Ag (Silver)	0	0	0	0	0
	Al (Aluminium)	3	2	2	4	2
	Cr (Chromium)	0	0	0	1	0
	Cu (Copper)	2	1	1	2	1
	Fe (Iron)	7	4	4	10	7
	Mo (Molybdenum)	4	4	3	0	1
	Ni (Nickel)	1	1	1	2	1
	Pb (Lead)	2	0	1	4	0
	Sn (Tin)	2	0	1	2	1
	Ti (Titanium)	0	0	0	0	0
Contaminant (ppm)	K (Potassium)	0	0	0	0	0
	Na (Sodium)	4	4	4	8	7
	Si (Silicon)	177	76	112	248	81
Additive (ppm)	B (Boron)	1	0	0	1	0
	Ba (Barium)	0	0	0	0	0
	Ca (Calcium)	4085	3914	3790	4379	3767
	Mg (Magnesium)	11	11	11	13	11
	P (Phosphorous)	4	4	3	5	5
	Zn (Zinc)	3	3	3	4	3

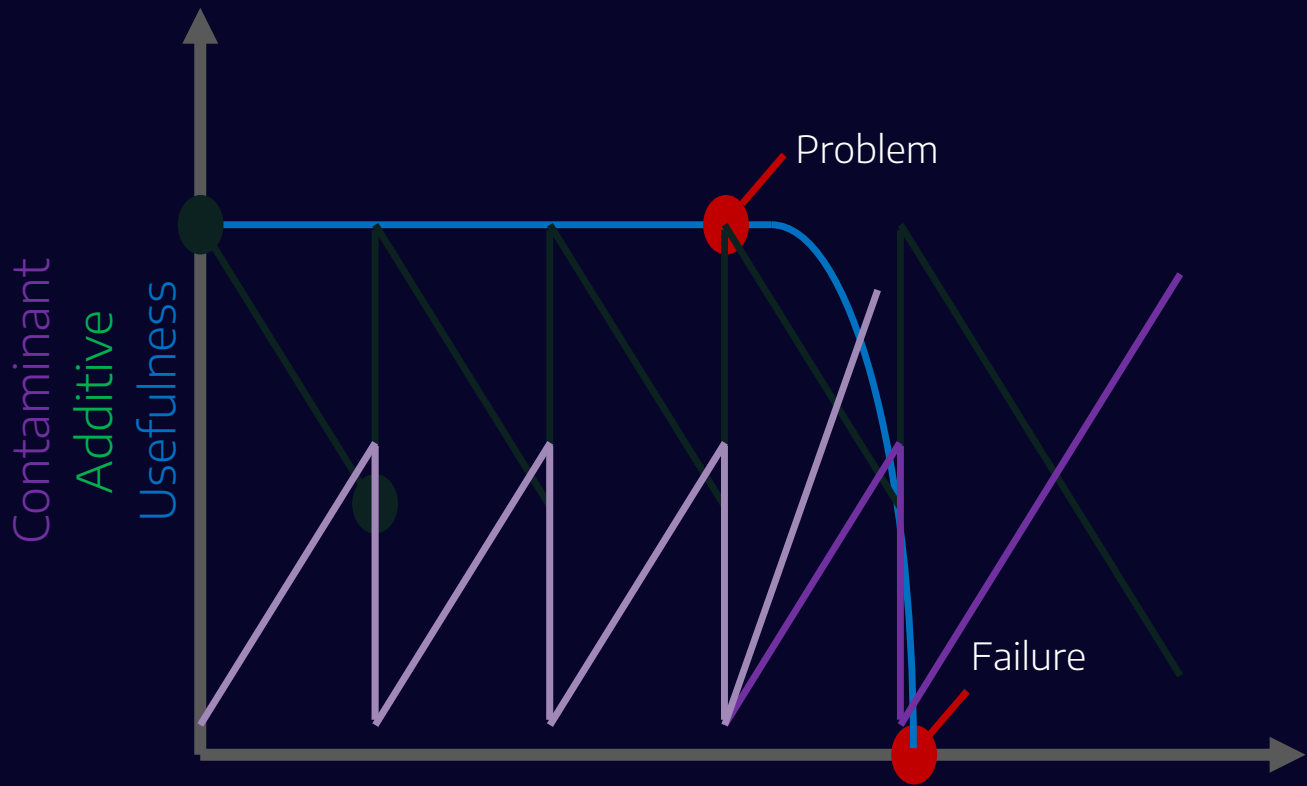

Overall Report Status = NORMAL						
Sample Info	Report Status	Caution	Normal	Normal	Alert	Normal
	Sample ID	156989048	156989060	156989101	156989206	156989348
	Bottle ID	s989048	s89060	s989101	s89206	s989348
	Lubricant	XYZ	XYZ	XYZ	XYZ	XYZ
	Sample Date	09-08-19	09-09-19	09-10-19	09-12-19	09-01-20
	Report Date	19-08-19	19-09-19	19-10-19	19-12-19	19-01-20
	Equipment Age	54206	54300	54758	54862	55001
	Equipment UOM	Hours	Hours	Hours	Hours	Hours
	Oil Changed	Yes	No	No	Yes	No
	Oil Age	486	97	299	525	141
	Oil UOM	Hours	Hours	Hours	Hours	Hours
	Make Up Volume				160	
	Volume UOM				Litres	
	Filter Changed	Yes	No	No	Yes	No
Lubricant	Contamination Rating	Caution	Normal	Normal	Alert	Normal
	Equipment Rating	Normal	Normal	Normal	Normal	Normal
	Oil Rating	Normal	Normal	Normal	Caution	Normal
	PQ Index	1	1	0	5	4
	SAE Grade	40	40	40	40	40
	Visc @100C	15.2	14.2	14.8	15.9	15.2
	Oxidation (Abs/cm)	9	6	8	13	8
	TAN (mg KOH/g)	2.39	1.66	2.31	3.02	2.25
	Nitration (Abs/cm)	1	1	1	3	3
	TBN (mg KOH/g)	8.3	9.0	8.4	7.7	8.5
	Soot (wt%)	0.13	0.11	0.15	0.19	0.19
	Water (vol%)	Not Detected	Not Detected	Not Detected	Not Detected	Not Detected
	Coolant Indicator	Not Detected	Not Detected	Not Detected	Not Detected	Not Detected
	Cl (Cl ppm - Xray)	104	50	85	104	47
Wear (ppm)	Ag (Silver)	0	0	0	0	0
	Al (Aluminium)	3	2	2	4	2
	Cr (Chromium)	0	0	0	1	0
	Cu (Copper)	2	1	1	2	1
	Fe (Iron)	7	4	4	10	7
	Mo (Molybdenum)	4	4	3	0	1
	Ni (Nickel)	1	1	1	2	1
	Pb (Lead)	2	0	1	4	0
	Sn (Tin)	2	0	1	2	1
	Ti (Titanium)	0	0	0	0	0
Contaminant (ppm)	K (Potassium)	0	0	0	0	0
	Na (Sodium)	4	4	4	8	7
	Si (Silicon)	177	76	112	248	81
Additive (ppm)	B (Boron)	1	0	0	1	0
	Ba (Barium)	0	0	0	0	0
	Ca (Calcium)	4085	3914	3790	4379	3767
	Mg (Magnesium)	11	11	11	13	11
	P (Phosphorous)	4	4	3	5	5
	Zn (Zinc)	3	3	3	4	3

Overall Report Status = NORMAL

Sample Info

Report Status	Caution	Normal	Normal	Alert	Normal
Sample ID	156989048	156989060	156989101	156989206	156989348
Bottle ID	s989048	s89060	s989101	s89206	s989348
Lubricant	XYZ	XYZ	XYZ	XYZ	XYZ
Sample Date	09-08-19	09-09-19	09-10-19	09-12-19	09-01-20
Report Date	19-08-19	19-09-19	19-10-19	19-12-19	19-01-20
Equipment Age	54200	54300	54758	54862	55001
Equipment UOM	Hours	Hours	Hours	Hours	Hours
Oil Changed	Yes	No	No	Yes	No
Oil Age	486	97	299	525	141
Oil UOM	Hours	Hours	Hours	Hours	Hours
Make Up Volume				160	
Volume UOM				Litres	
Filter Changed	Yes	No	No	Yes	No

Contaminant Additive Usefulness

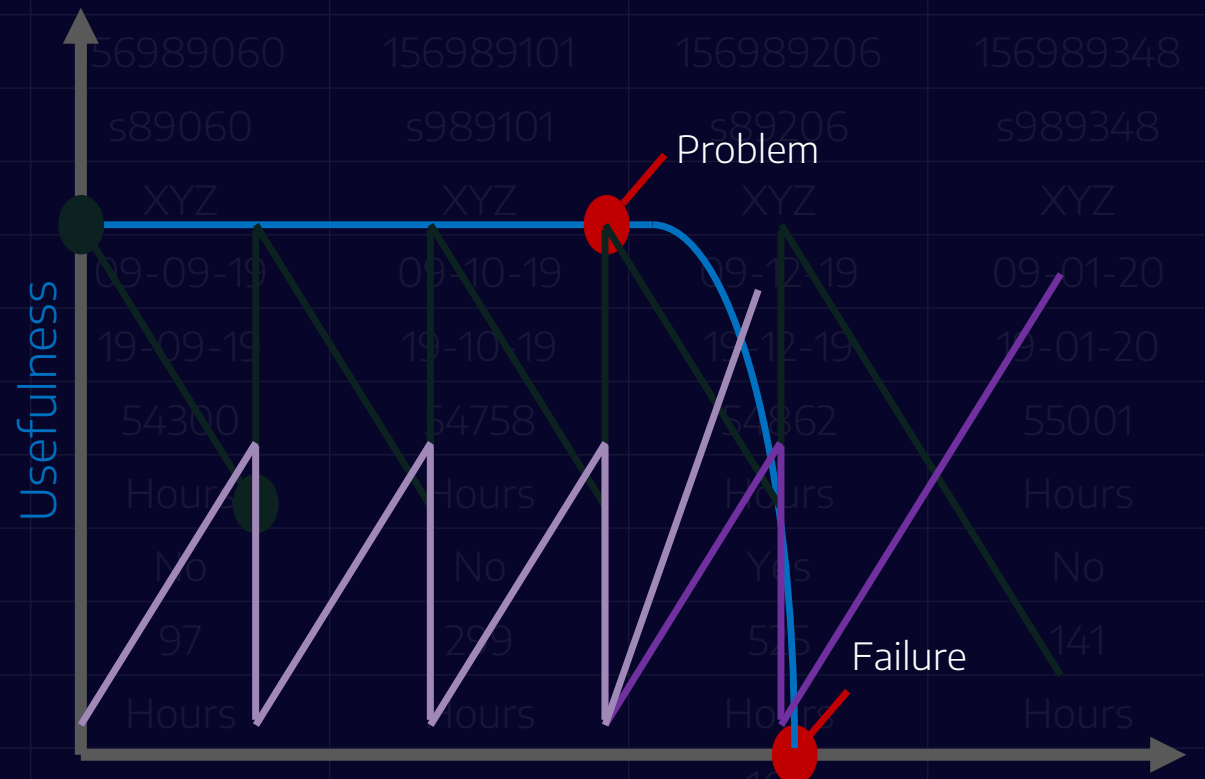

Contamination Rating	Caution	Normal	Normal	Alert	Normal
Equipment Rating	Normal	Normal	Normal	Normal	Normal

Overall Report Status = NORMAL

Sample Info

Report Status
Sample ID
Bottle ID
Lubricant
Sample Date
Report Date
Equipment Age
Equipment UOM
Oil Changed
Oil Age
Oil UOM
Make Up Volume
Volume UOM
Filter Changed

Caution	Normal	Normal	Alert	Normal
156989048	156989060	156989101	156989206	156989348
s989048	s89060	s989101	s89206	s989348
XYZ	XYZ	XYZ	XYZ	XYZ
09-08-19	09-09-19	09-10-19	09-12-19	09-01-20
19-08-19	19-09-19	19-10-19	19-12-19	19-01-20
54200	54300	54758	54862	55001
Hours	Hours	Hours	Hours	Hours
Yes	No	No	Yes	No
486	97	299	525	141
Hours	Hours	Hours	Hours	Hours
			160	
			Litres	
Yes	No	No	Yes	No

Contaminant Additive Usefulness

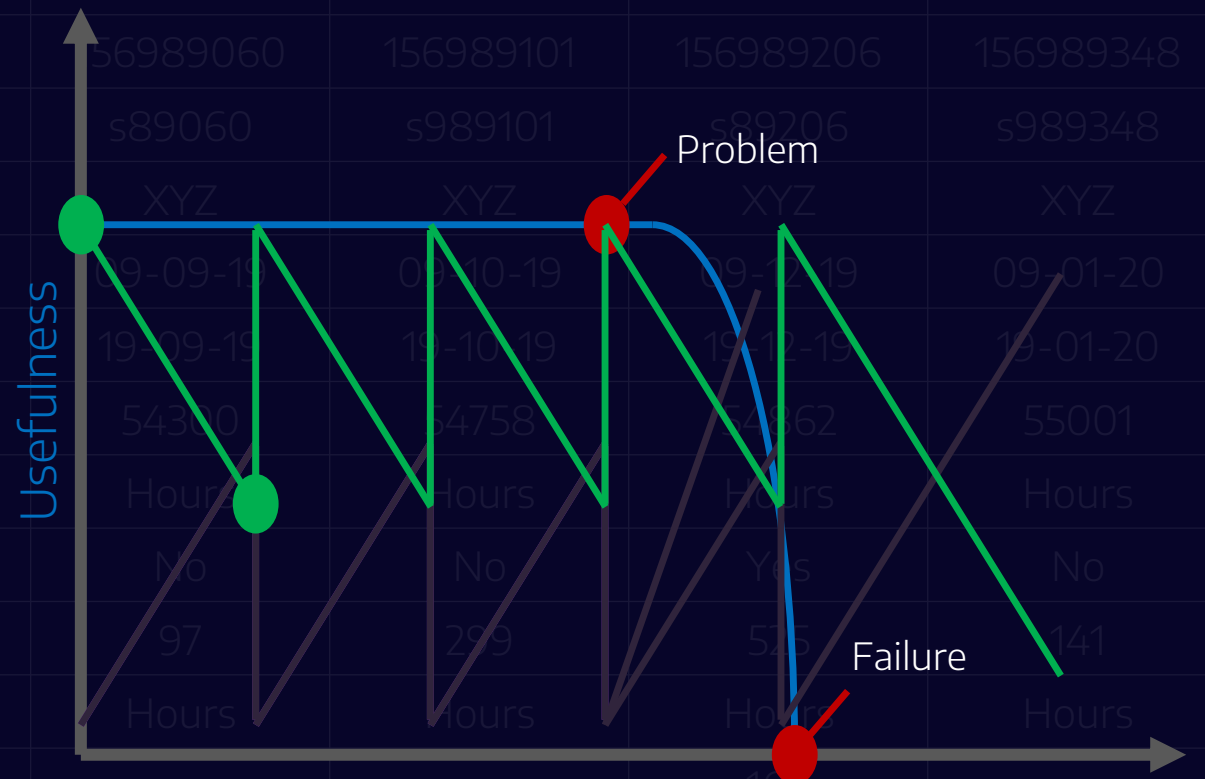

Problem

Failure

Contamination Rating
Equipment Rating

Caution	Normal	Normal	Alert	Normal
Normal	Normal	Normal	Normal	Normal

Overall Report Status = NORMAL

Sample Info

Report Status
Sample ID
Bottle ID
Lubricant
Sample Date
Report Date
Equipment Age
Equipment UOM
Oil Changed
Oil Age
Oil UOM
Make Up Volume
Volume UOM
Filter Changed

Contamination Rating
Equipment Rating

Caution	Normal	Normal	Alert	Normal
156989048	156989060	156989101	156989206	156989348
s989048	s89060	s989101	s89905	s989348
XYZ	XYZ	XYZ	XYZ	XYZ
09-08-19	09-09-19	09-10-19	09-12-19	09-01-20
19-08-19	19-09-19	19-10-19	19-12-19	19-01-20
54200	54300	54758	54862	55001
Hours	Hours	Hours	Hours	Hours
Yes	No	No	Yes	No
486	97	299	525	141
Hours	Hours	Hours	Hours	Hours
			160	
			Litres	
Yes	No	No	Yes	No
Caution	Normal	Normal	Alert	Normal
Normal	Normal	Normal	Normal	Normal

Contaminant Additive

Usefulness

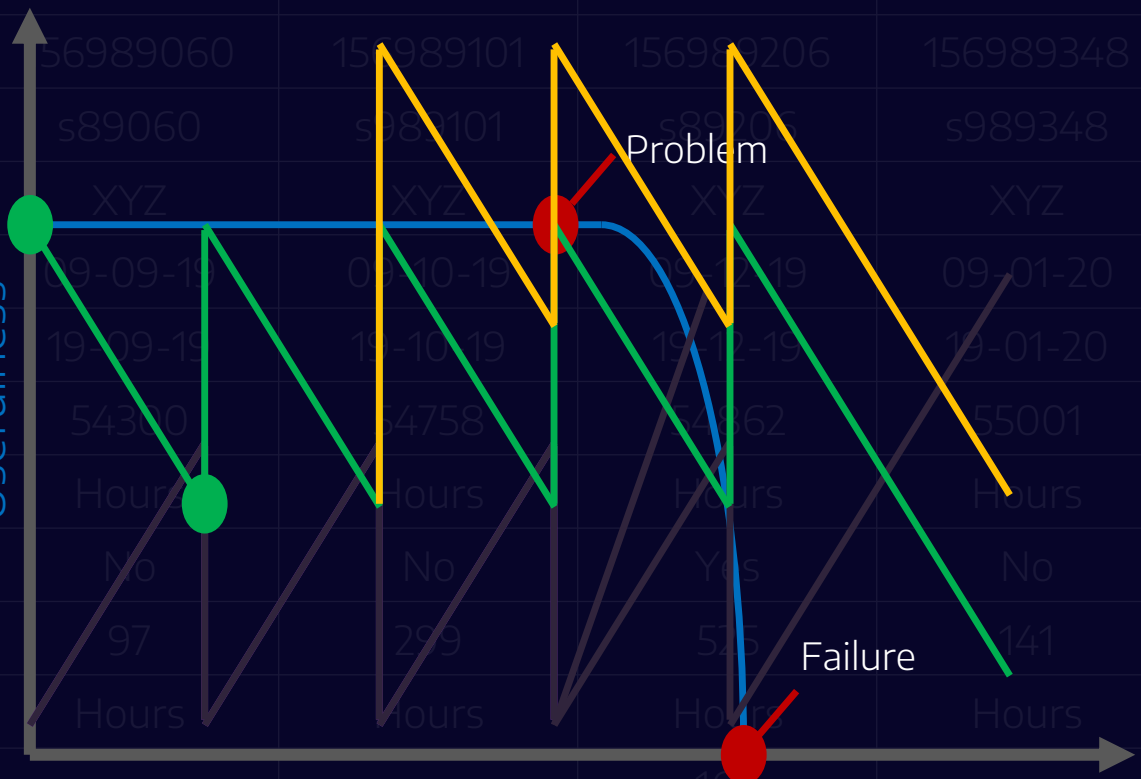

Overall Report Status = NORMAL

Sample Info



Report Status
Sample ID
Bottle ID
Lubricant
Sample Date
Report Date
Equipment Age
Equipment UOM
Oil Changed
Oil Age
Oil UOM
Make Up Volume
Volume UOM
Filter Changed

Contamination Rating
Equipment Rating

Caution	Normal	Normal	Alert	Normal
156989048	156989060	156989101	156989206	156989348
s989048	s89060	s989101	s89206	s989348
XYZ	XYZ	XYZ	XYZ	XYZ
09-08-19	09-09-19	09-10-19	09-12-19	09-01-20
19-08-19	19-09-19	19-10-19	19-12-19	19-01-20
54200	54300	54758	54862	55001
Hours	Hours	Hours	Hours	Hours
Yes	No	No	Yes	No
486	97	299	525	141
Hours	Hours	Hours	Hours	Hours
			160	
			Litres	
Yes	No	No	Yes	No

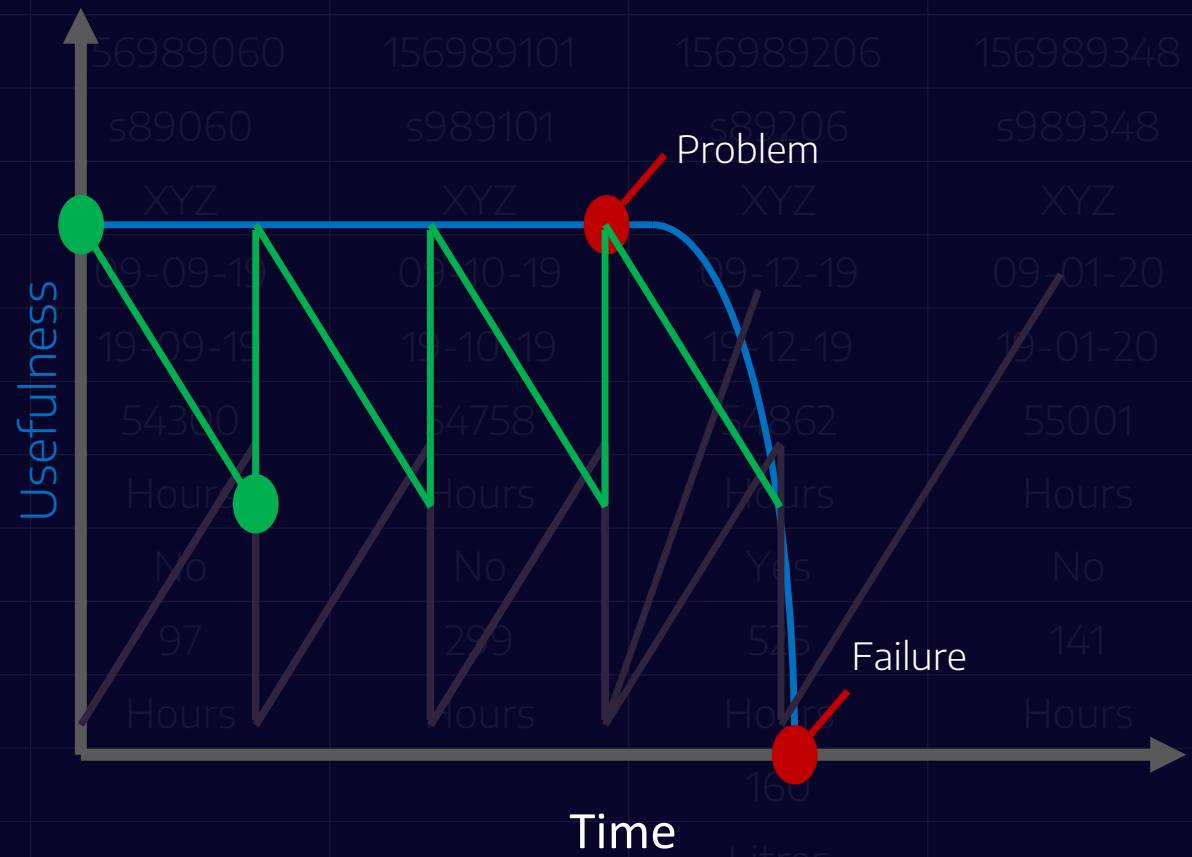

Overall Report Status = NORMAL

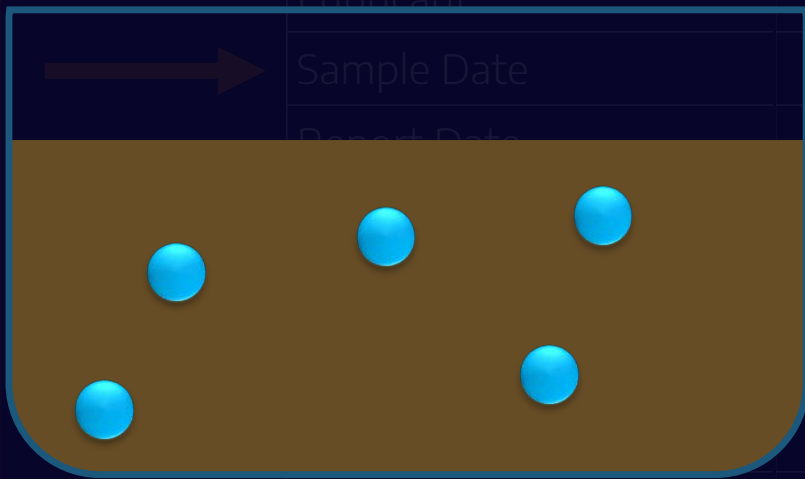

Report Status	Caution	Normal	Normal	Alert	Normal
Sample ID	156989048	156989060	156989101	156989206	156989348
Bottle ID	s989048	s89060	s989101	s99206	s989348
Lubricant	XYZ	XYZ	XYZ	XYZ	XYZ
Sample Date	09-08-19	09-09-19	09-10-19	09-12-19	09-01-20
Report Date	19-08-19	19-09-19	19-10-19	19-12-19	19-01-20
Contaminant	54200	54300	54758	54862	55001
Additive	Hours	Hours	Hours	Hours	Hours
Usefulness	Yes	No	No	Yes	No
Failure	486	97	299	525	141
Oil UOM	Hours	Hours	hours	Hours	Hours
Make Up Volume				160	
Volume UOM				Litres	
Filter Changed	Yes	No	No	Yes	No
Contamination Rating	Caution	Normal	Normal	Alert	Normal
Equipment Rating	Normal	Normal	Normal	Normal	Normal

Contaminant  
Additive

Usefulness

What kind of Time?

Problem

Failure



Overall Report Status = NORMAL

Sample Info



Report Status
Sample ID
Bottle ID
Lubricant
Sample Date
Report Date
Equipment Age
Equipment UOM
Oil Changed
Oil Age
Oil UOM
Make Up Volume
Volume UOM
Filter Changed

Caution	Normal	Normal	Alert	Normal
156989048	156989060	156989101	156989206	156989348
s989048	s89060	s989101	s89206	s989348
XYZ	XYZ	XYZ	XYZ	XYZ
09-08-19	09-09-19	09-10-19	09-12-19	09-01-20
19-08-19	19-09-19	19-10-19	19-12-19	19-01-20
54200	54300	54758	54862	55001
Hours	Hours	Hours	Hours	Hours
Yes	No	No	Yes	No
486	97	299	525	141
Hours	Hours	Hours	Hours	Hours
			160	
			Litres	
Yes	No	No	Yes	No

Contaminant Additive

Usefulness

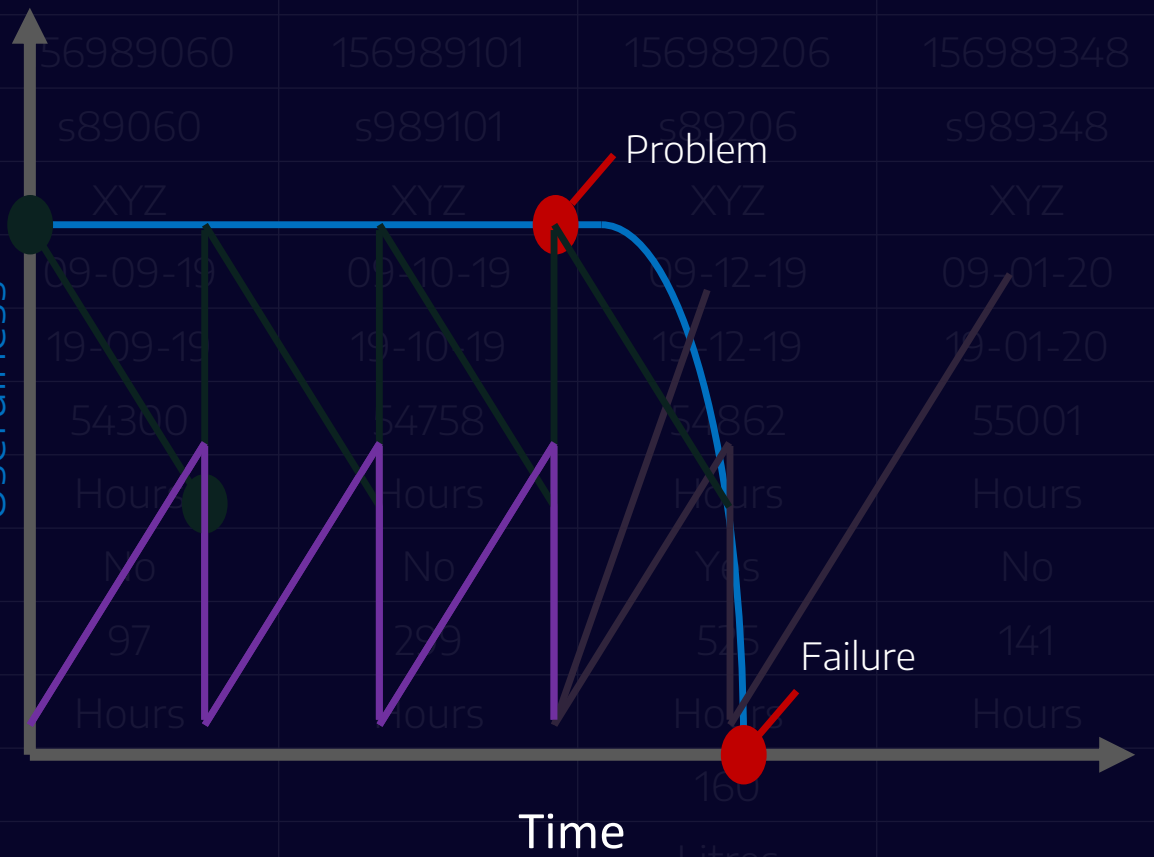

Time

Contamination Rating
Equipment Rating

Caution	Normal	Normal	Alert	Normal
Normal	Normal	Normal	Normal	Normal

Overall Report Status = NORMAL

Sample Info



Report Status
Sample ID
Bottle ID
Lubricant
Sample Date
Report Date
Equipment Age
Equipment UOM
Oil Changed
Oil Age
Oil UOM
Make Up Volume
Volume UOM
Filter Changed

Caution	Normal	Normal	Alert	Normal
156989048	156989060	156989101	156989206	156989348
s989048	s89060	s989101	s89206	s989348
XYZ	XYZ	XYZ	XYZ	XYZ
09-08-19	09-09-19	09-10-19	09-12-19	09-01-20
19-08-19	19-09-19	19-10-19	19-12-19	19-01-20
54200	54300	54758	54862	55001
Hours	Hours	Hours	Hours	Hours
Yes	No	No	Yes	No
486	97	299	525	141
Hours	Hours	Hours	Hours	Hours
			160	
			Litres	
Yes	No	No	Yes	No

Contaminant Additive

Usefulness

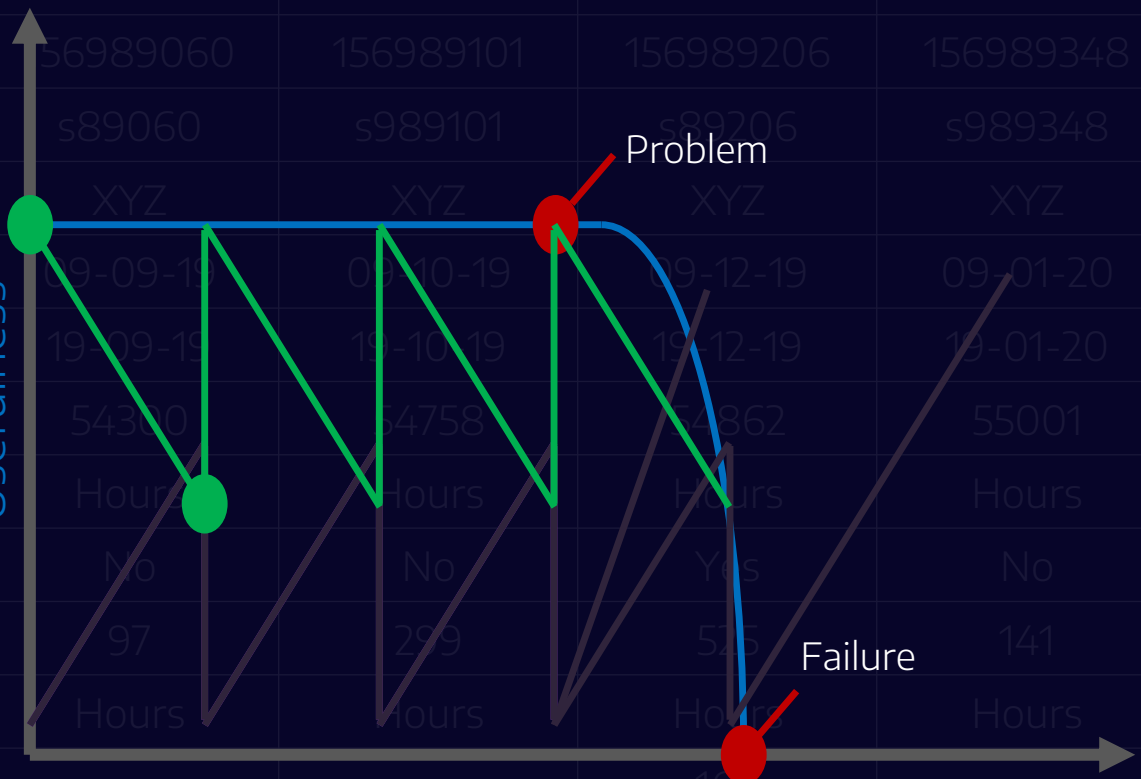

Time

Contamination Rating
Equipment Rating

Caution	Normal	Normal	Alert	Normal
Normal	Normal	Normal	Normal	Normal

Overall Report Status = NORMAL

Sample Info

Report Status
Sample ID
Bottle ID
Lubricant
Sample Date
Report Date
Equipment Age
Equipment UOM
Oil Changed
Oil Age
Oil UOM
Make Up Volume
Volume UOM
Filter Changed

Caution	Normal	Normal	Alert	Normal
156989048	156989060	156989101	156989206	156989348
s989048	s89060	s989101	s89206	s989348
XYZ	XYZ	XYZ	XYZ	XYZ
09-08-19	09-09-19	09-10-19	09-12-19	09-01-20
19-08-19	19-09-19	19-10-19	19-12-19	19-01-20
54200	54300	54758	54862	55001
Hours	Hours	Hours	Hours	Hours
Yes	No	No	Yes	No
486	97	299	525	141
Hours	Hours	Hours	Hours	Hours
			160	
			Litres	
Yes	No	No	Yes	No

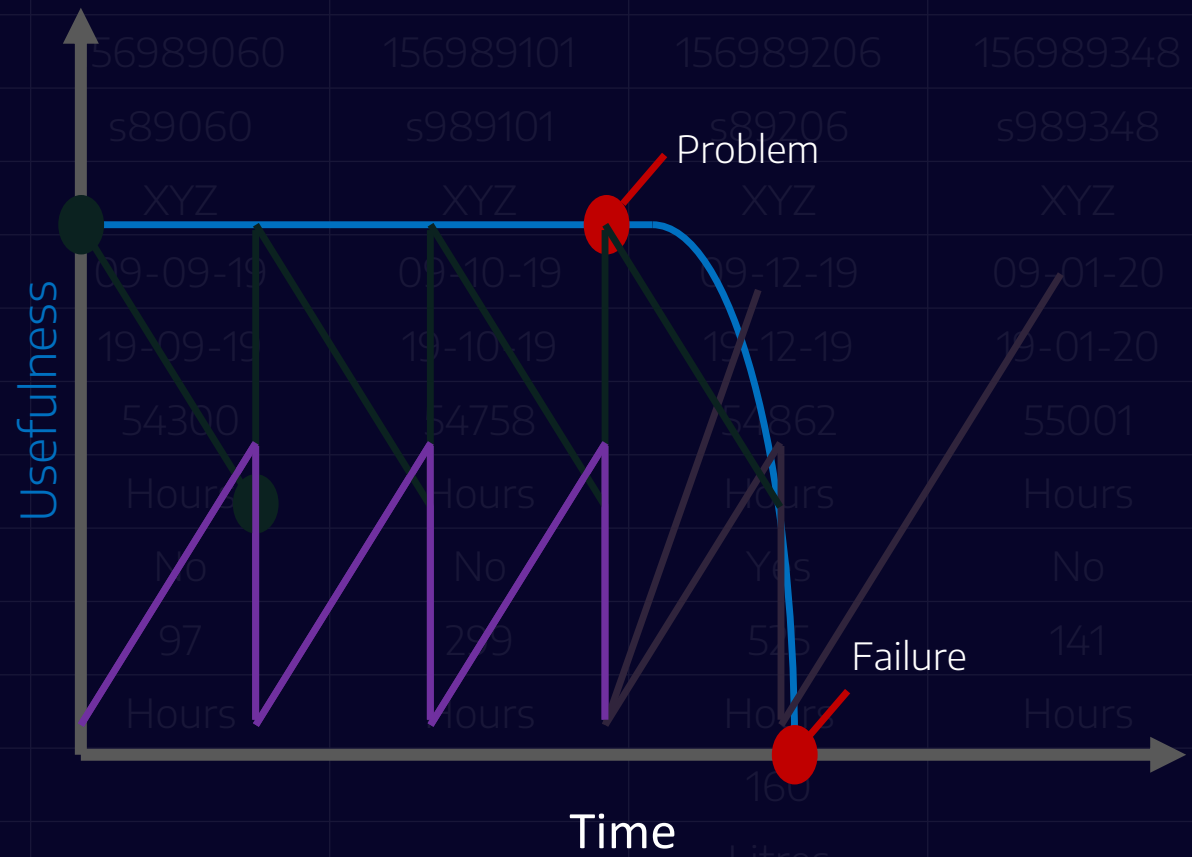

Time

Contamination Rating
Equipment Rating

Caution	Normal	Normal	Alert	Normal
Normal	Normal	Normal	Normal	Normal

Overall Report Status = NORMAL

Sample Info

Report Status
Sample ID
Bottle ID
Lubricant
Sample Date
Report Date
Equipment Age
Equipment UOM
Oil Changed
Oil Age
Oil UOM
Make Up Volume
Volume UOM
Filter Changed
Contamination Rating
Equipment Rating

Report Status	Caution	Normal	Normal	Alert	Normal
Sample ID	156989048	156989060	156989101	156989206	156989348
Bottle ID	s989048	s89060	s989101	s89206	s989348
Lubricant	XYZ	XYZ	XYZ	XYZ	XYZ
Sample Date	09-08-19	09-09-19	09-10-19	09-12-19	09-01-20
Report Date	19-08-19	19-09-19	19-10-19	19-12-19	19-01-20
Equipment Age	54200	54300	54758	54862	55001
Equipment UOM	Hours	Hours	Hours	Hours	Hours
Oil Changed	Yes	No	No	Yes	No
Oil Age	486	97	299	525	141
Oil UOM	Hours	Hours	Hours	Hours	Hours
Make Up Volume	160	160	160	160	160
Volume UOM	Litres	Litres	Litres	Litres	Litres
Filter Changed	Yes	No	No	Yes	No
Contamination Rating	Caution	Normal	Normal	Alert	Normal
Equipment Rating	Normal	Normal	Normal	Normal	Normal

Contaminant Additive Usefulness

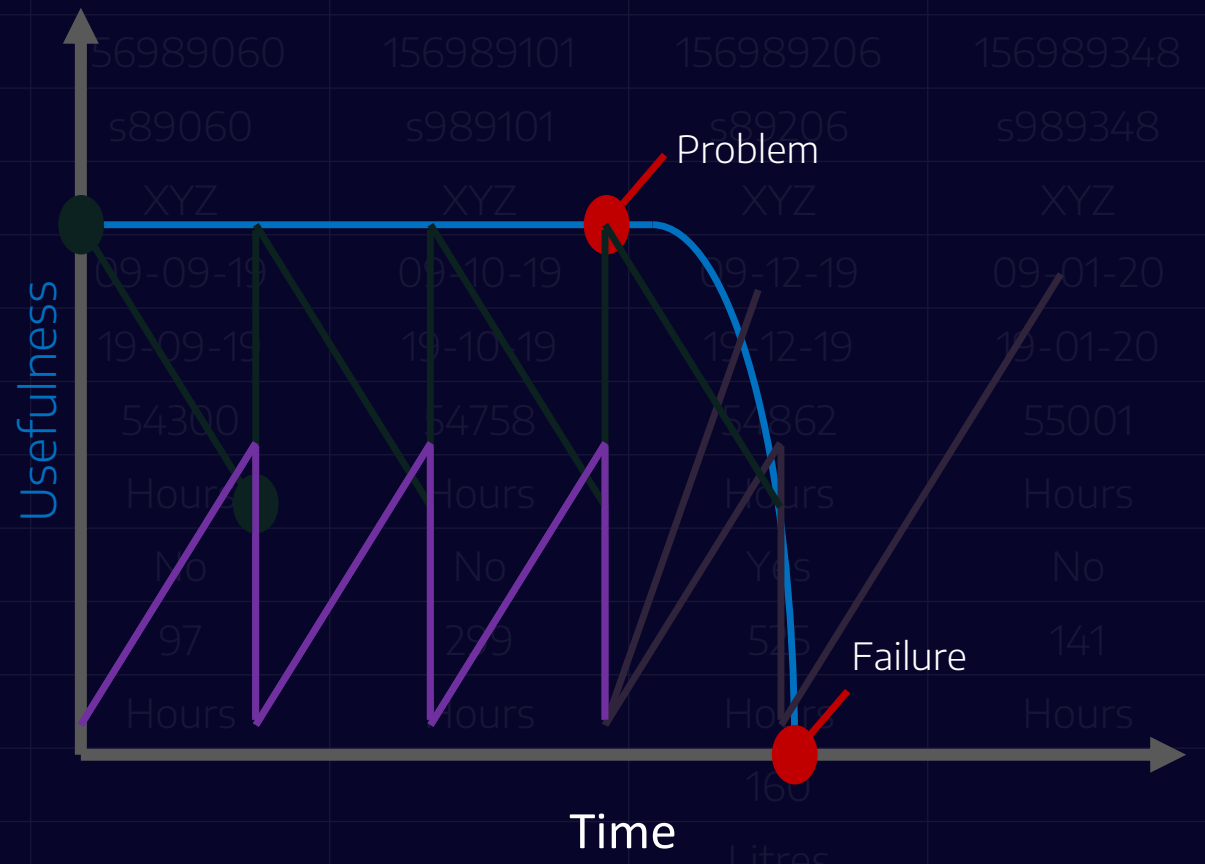

Overall Report Status = NORMAL

Sample Info



Report Status
Sample ID
Bottle ID
Lubricant
Sample Date
Report Date
Equipment Age
Equipment UOM
Oil Changed
Oil Age
Oil UOM
Make Up Volume
Volume UOM
Filter Changed
Contamination Rating
Equipment Rating

Caution	Normal	Normal	Alert	Normal
156989048	156989060	156989101	156989206	156989348
s989048	s89060	s989101	s89206	s989348
XYZ	XYZ	XYZ	XYZ	XYZ
09-08-19	09-09-19	09-10-19	09-12-19	09-01-20
19-08-19	19-09-19	19-10-19	19-12-19	19-01-20
54200	54300	54758	54862	55001
Hours	Hours	Hours	Hours	Hours
Yes	No	No	Yes	No
486	97	299	525	141
Hours	Hours	Hours	Hours	Hours
			160	
			Litres	
Yes	No	No	Yes	No
Caution	Normal	Normal	Alert	Normal
Normal	Normal	Normal	Normal	Normal

Contaminant Additive

Usefulness

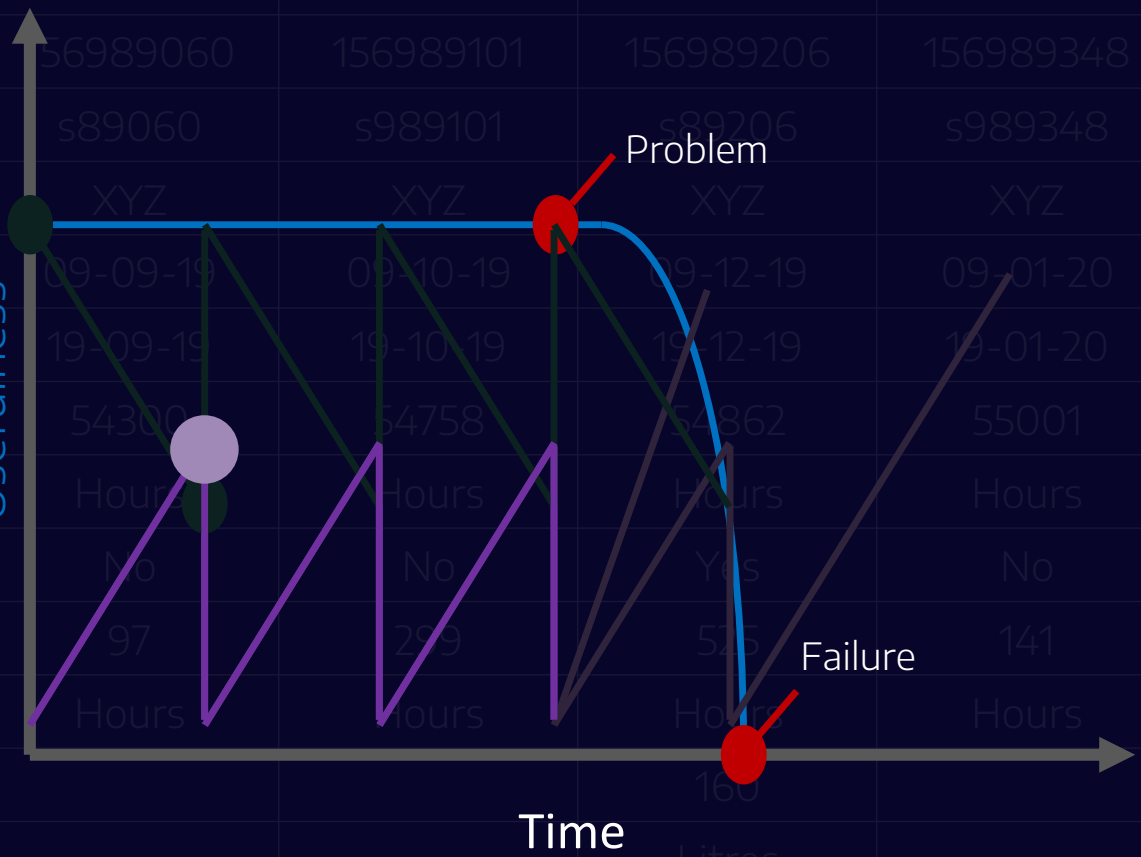

Overall Report Status = NORMAL

Sample Info



Report Status
Sample ID
Bottle ID
Lubricant
Sample Date
Report Date
Equipment Age
Equipment UOM
Oil Changed
Oil Age
Oil UOM
Make Up Volume
Volume UOM
Filter Changed

Caution	Normal	Normal	Alert	Normal
156989048	156989060	156989101	156989206	156989348
s989048	s89060	s989101	s89206	s989348
XYZ	XYZ	XYZ	XYZ	XYZ
09-08-19	09-09-19	09-10-19	09-12-19	09-01-20
19-08-19	19-09-19	19-10-19	19-12-19	19-01-20
54200	54300	54758	54862	55001
Hours	Hours	Hours	Hours	Hours
Yes	No	No	Yes	No
486	97	299	525	141
Hours	Hours	Hours	Hours	Hours
			160	
			Litres	
Yes	No	No	Yes	No

Contaminant Additive Usefulness

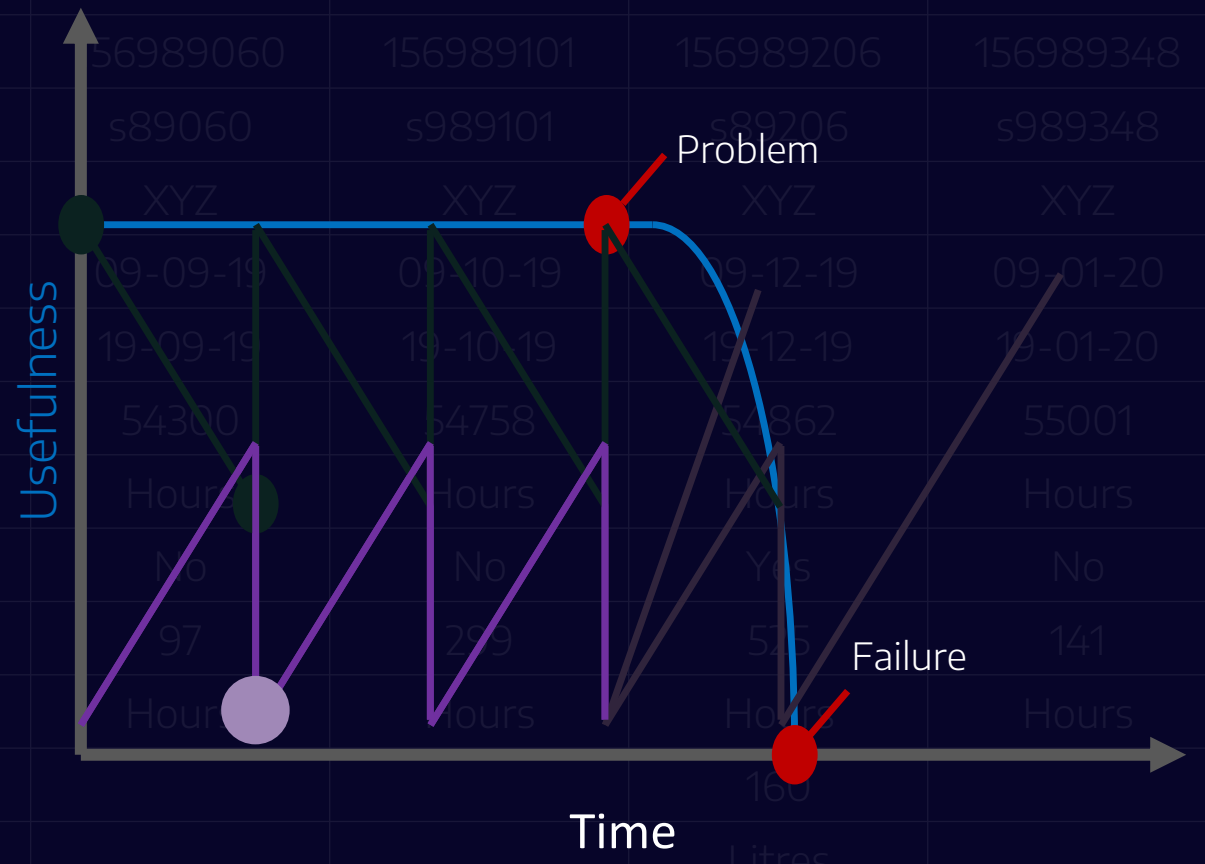

Time

Contamination Rating
Equipment Rating

Caution	Normal	Normal	Alert	Normal
Normal	Normal	Normal	Normal	Normal

Overall Report Status = NORMAL

Sample Info



Report Status
Sample ID
Bottle ID
Lubricant
Sample Date
Report Date
Equipment Age
Equipment UOM
Oil Changed
Oil Age
Oil UOM
Make Up Volume
Volume UOM
Filter Changed
Contamination Rating
Equipment Rating

Caution	Normal	Normal	Alert	Normal
156989048	156989060	156989101	156989206	156989348
s989048	s89060	s989101	s89206	s989348
XYZ	XYZ	XYZ	XYZ	XYZ
09-08-19	09-09-19	09-10-19	09-12-19	09-01-20
19-08-19	19-09-19	19-10-19	19-12-19	19-01-20
54200	54300	54758	54862	55001
Hours	Hours	Hours	Hours	Hours
Yes	No	No	Yes	No
486	97	299	525	141
Hours	Hours	Hours	Hours	Hours
Yes	No	No	Yes	No
Caution	Normal	Normal	Alert	Normal
Normal	Normal	Normal	Normal	Normal

Contaminant Additive Usefulness

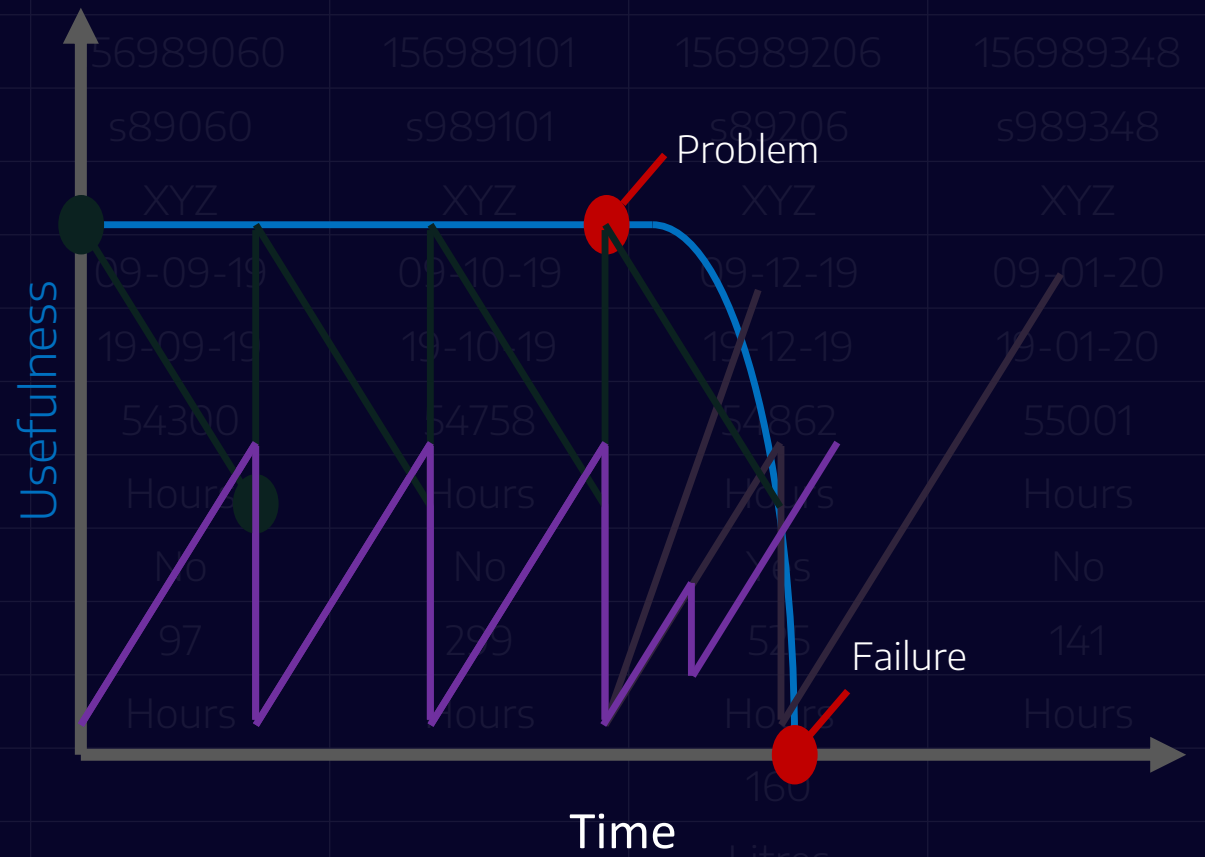

TAN / TBN / Oxidation

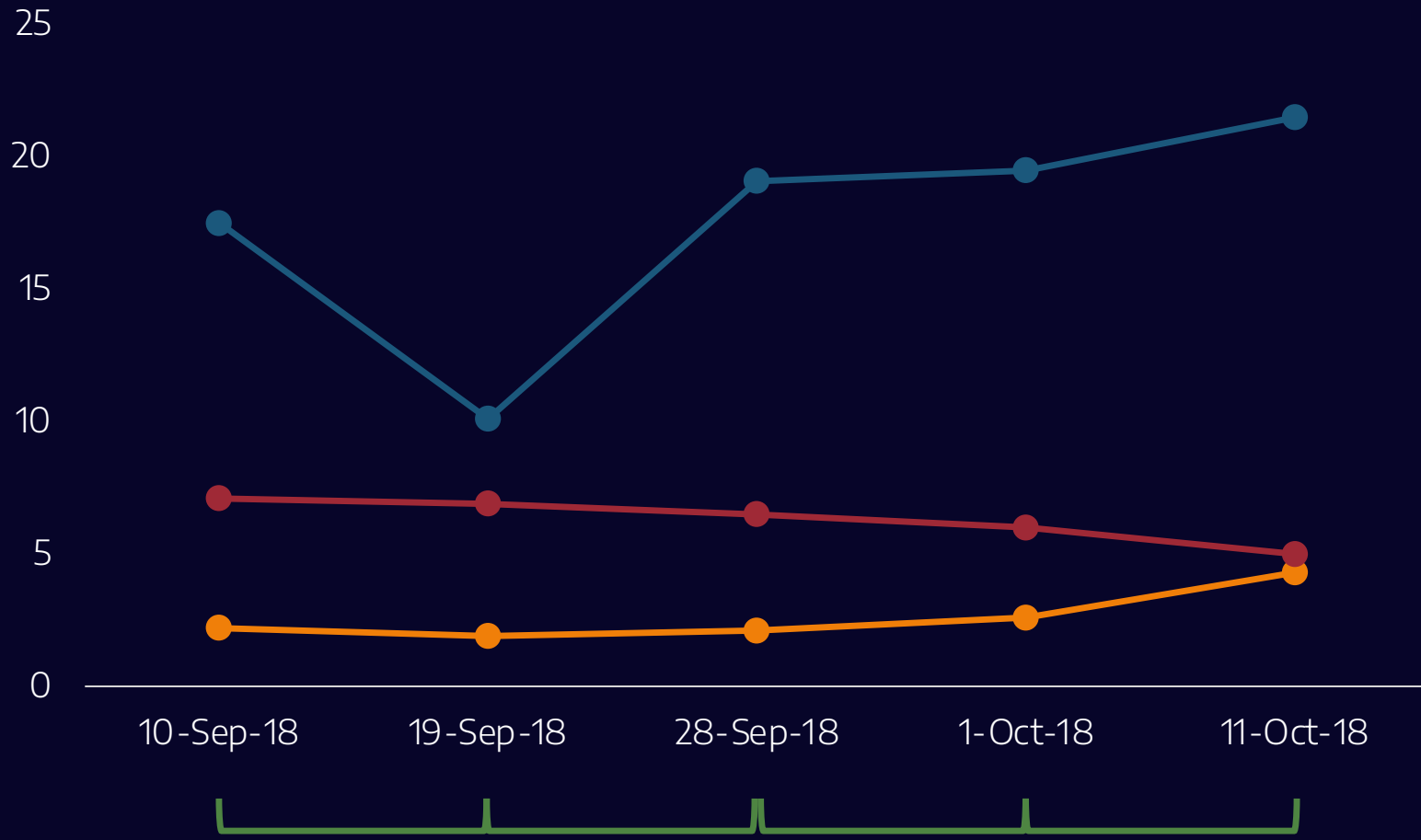



TAN / TBN / Oxidation

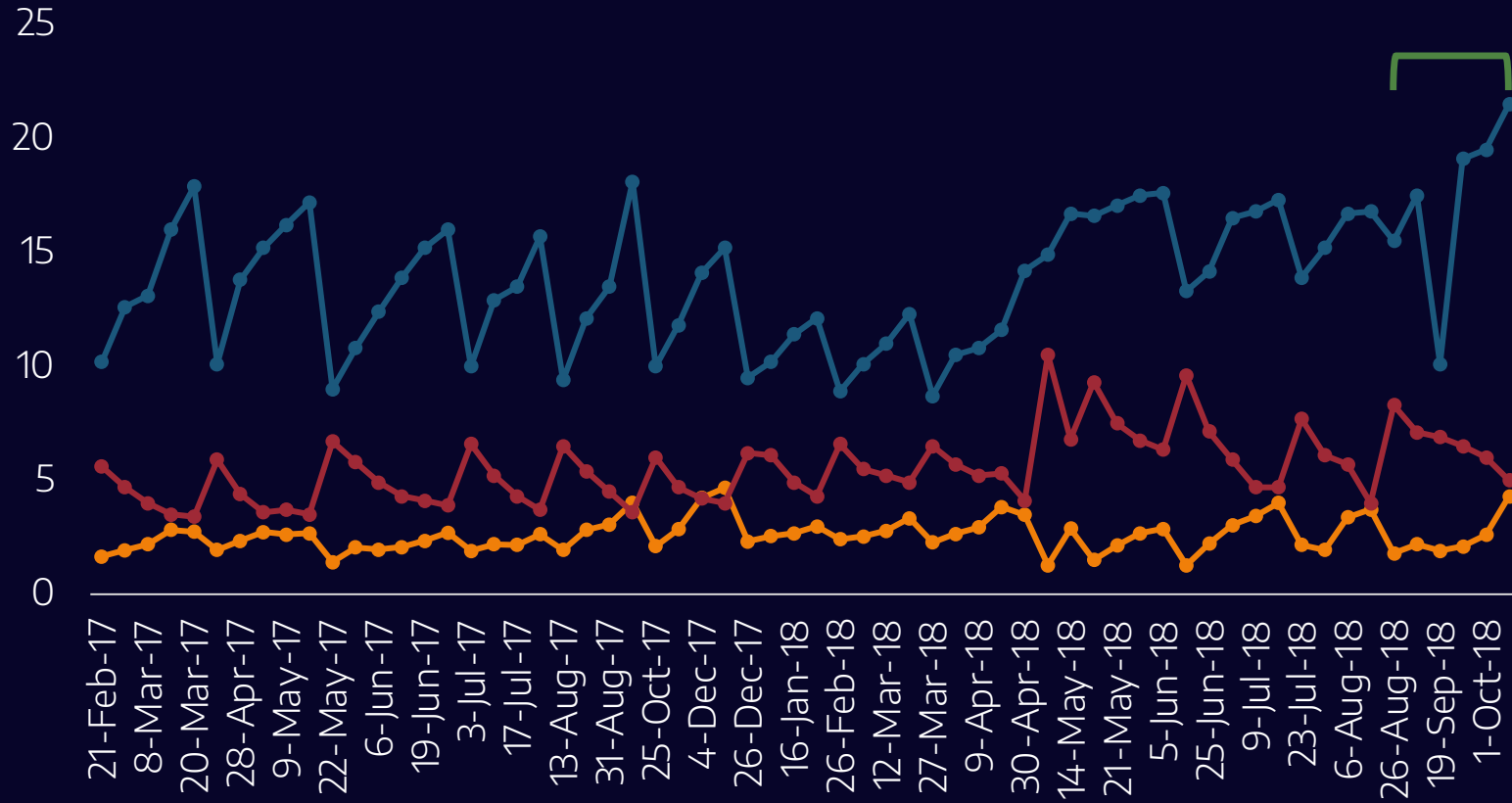

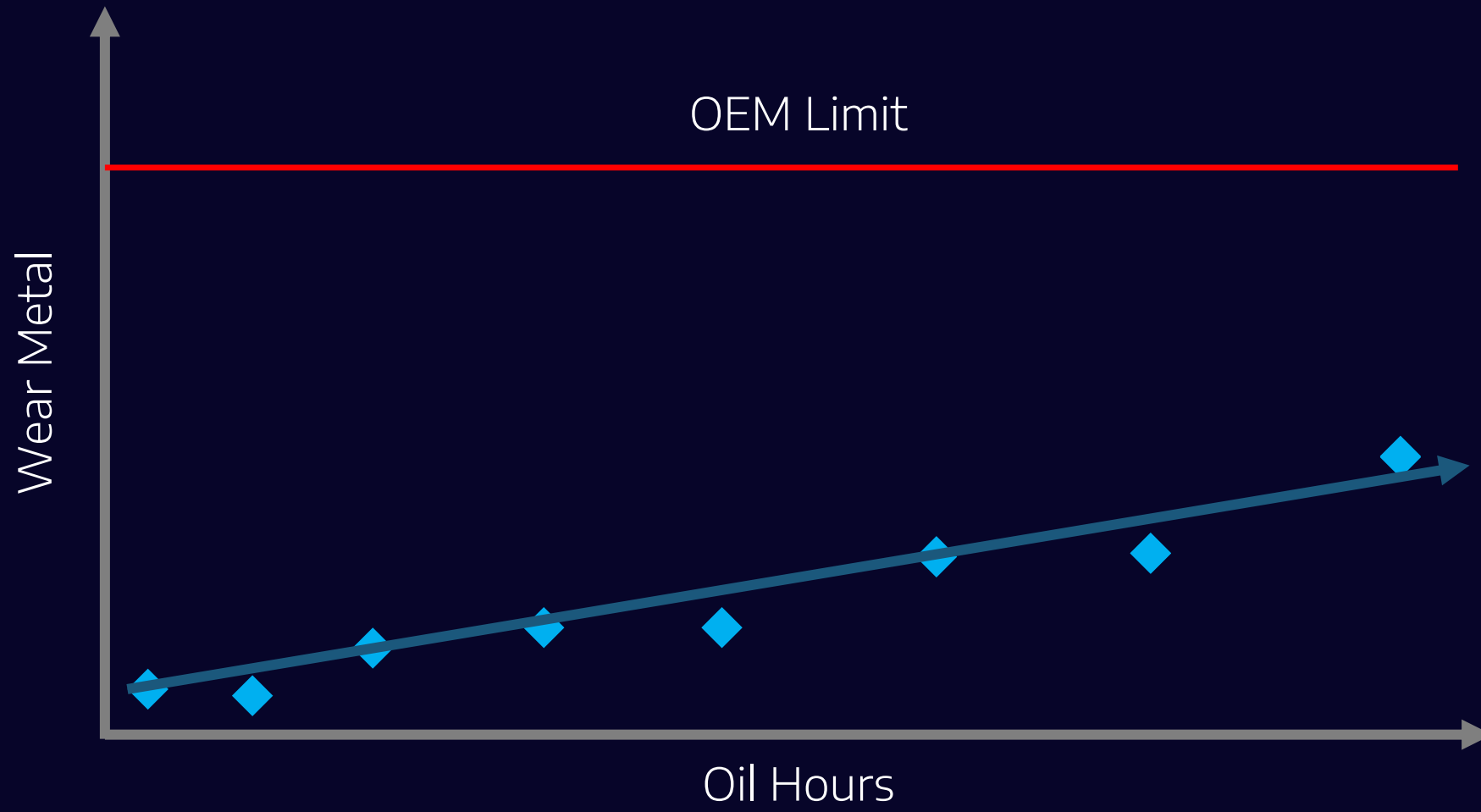

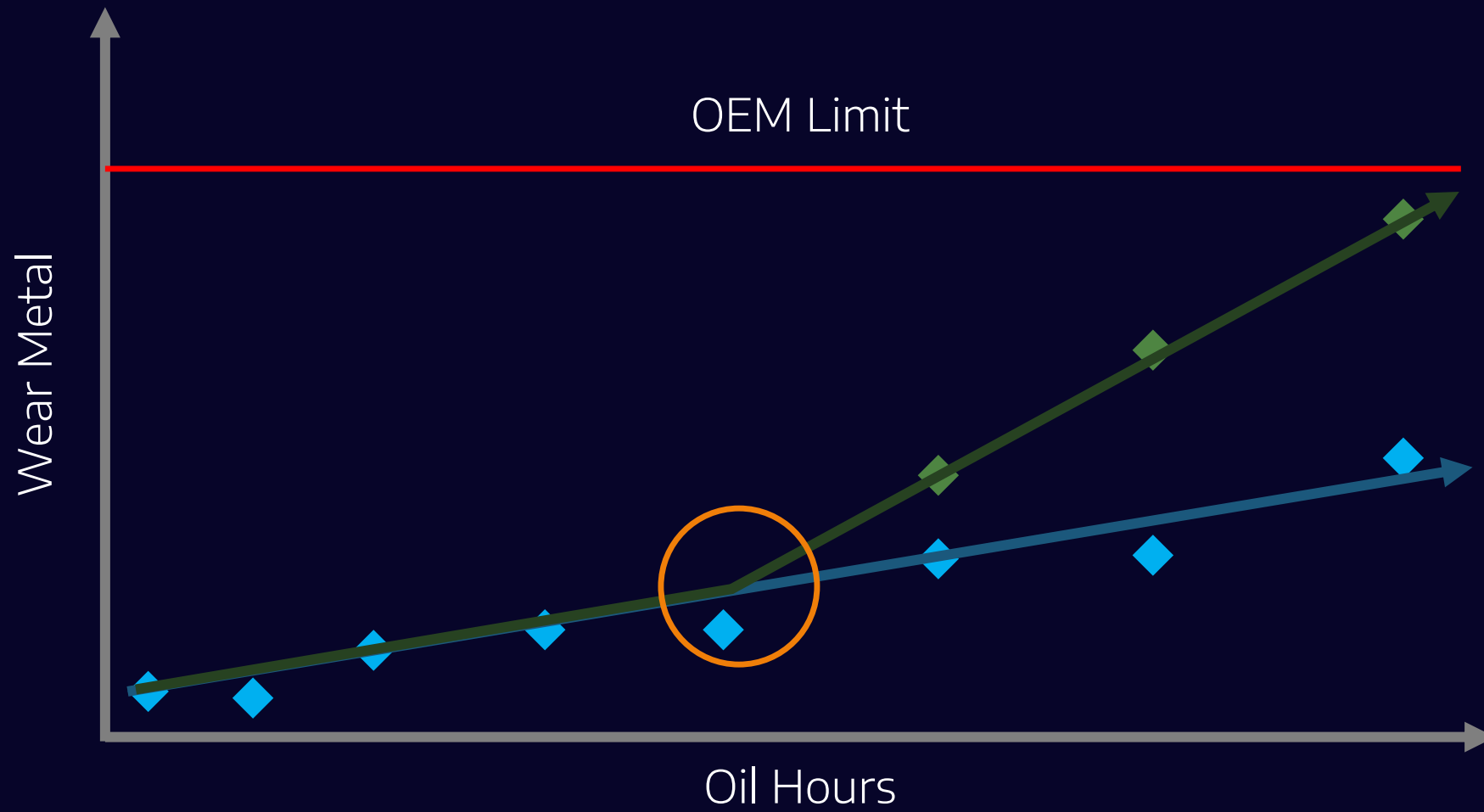

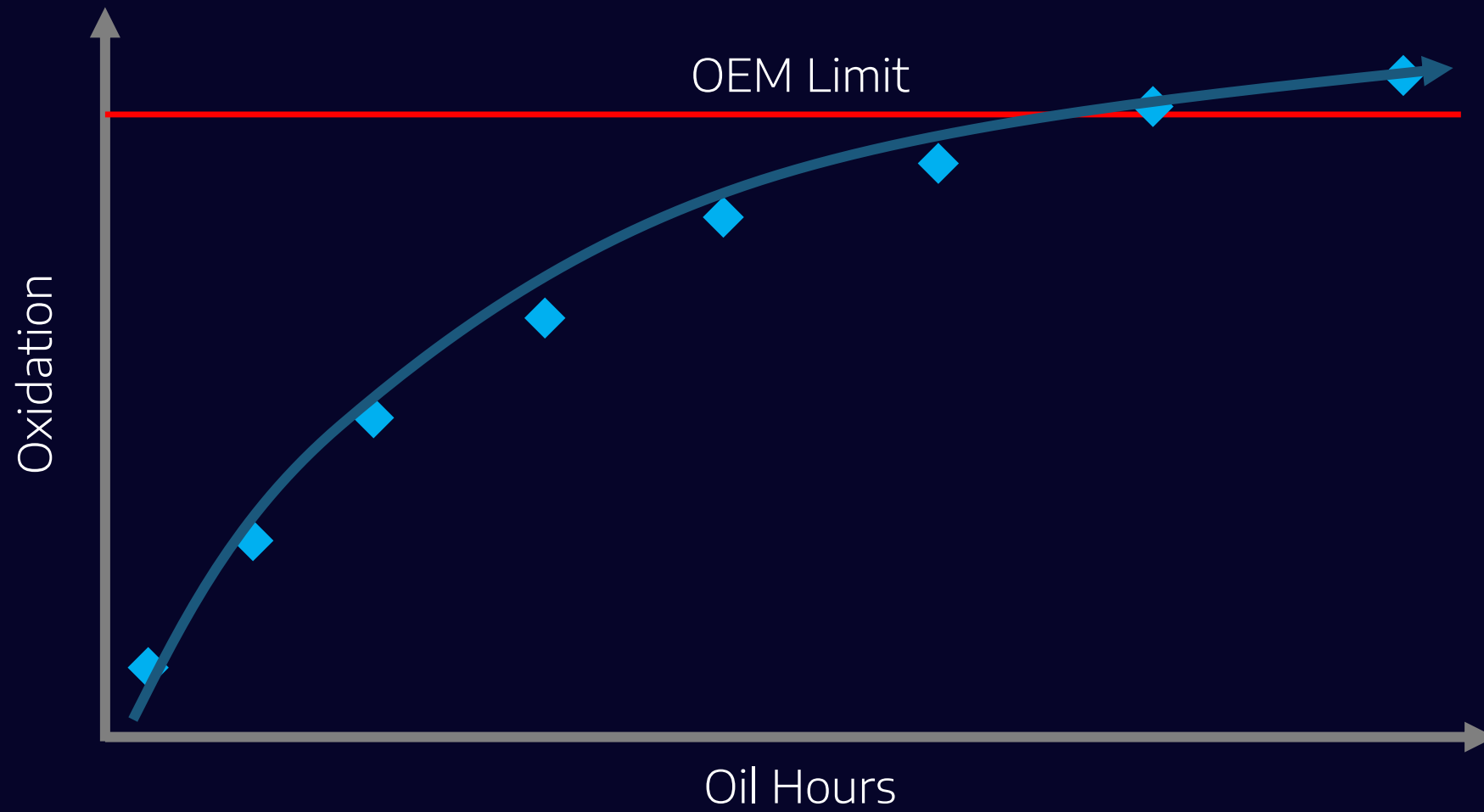

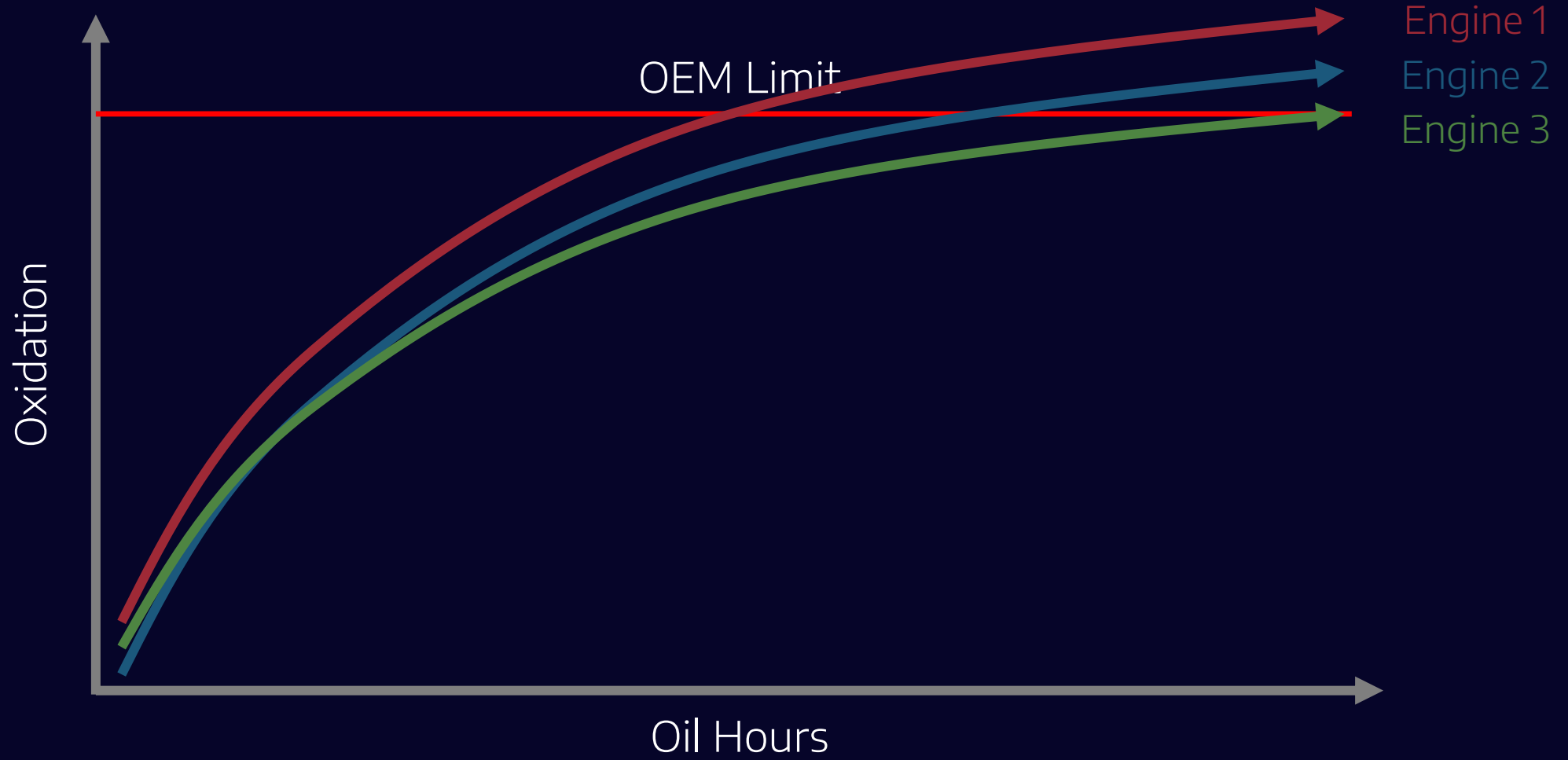

Engine 1  
Engine 2  
Engine 3

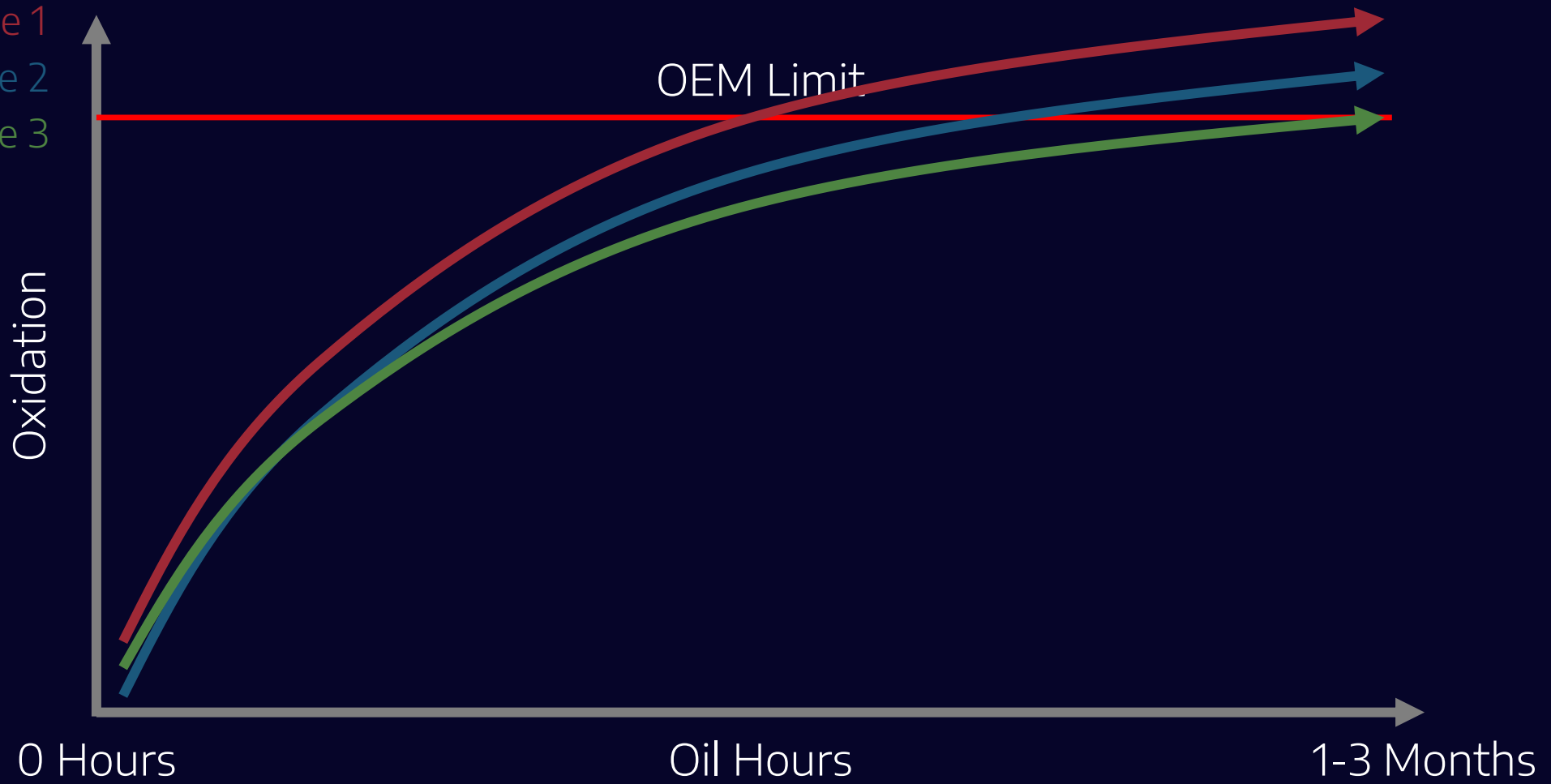

Engine 1  
Engine 2  
Engine 3

Oxidation

0 Hours

Oil Hours

1-3 Months

OEM Limit







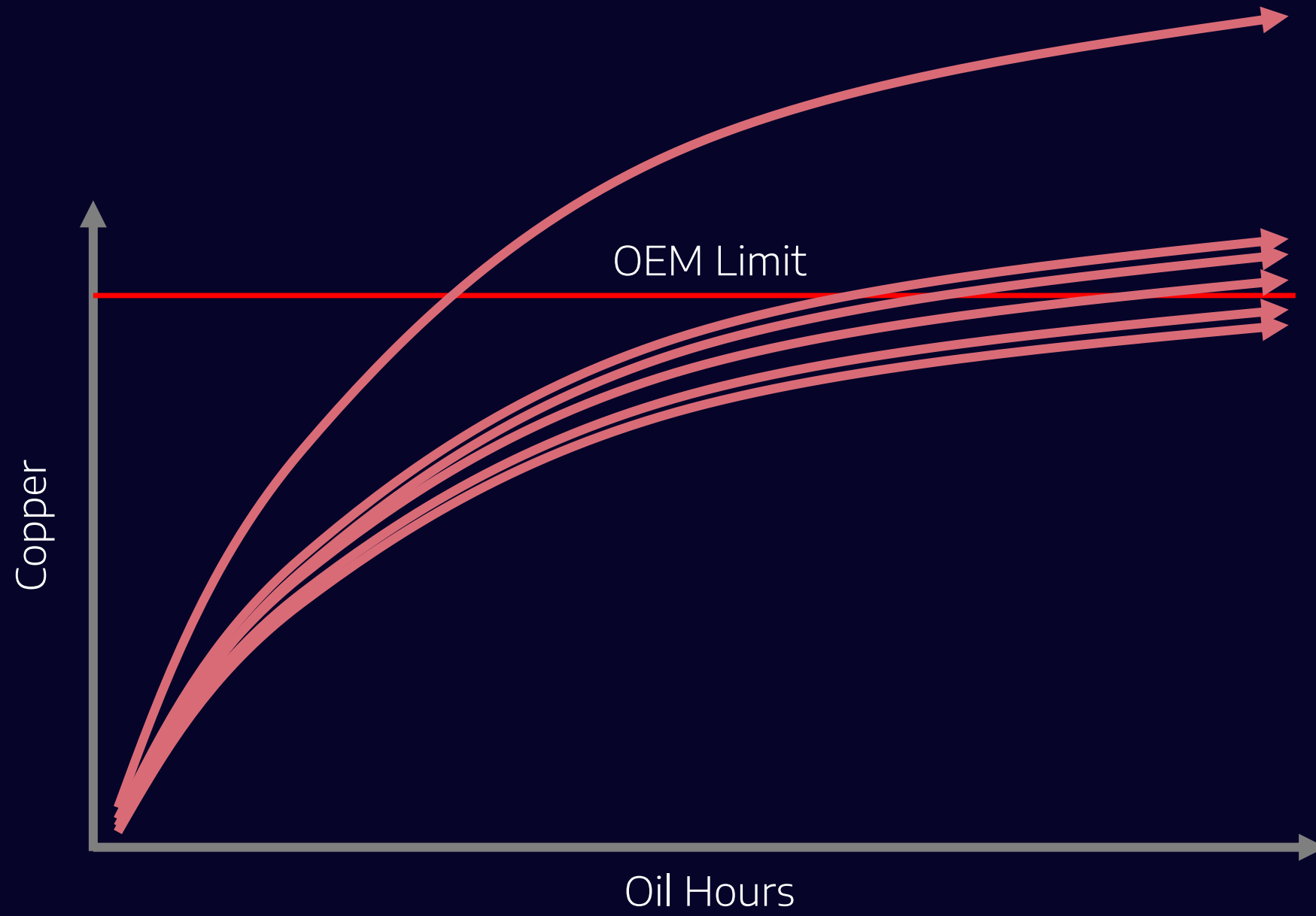

Independent Variable	Dependent Variables
Hours	Viscosity, Oxidation, TAN, Iron, Aluminium
Oxidation	Viscosity, TAN
TAN	TBN, IpH, Copper, Lead
Silicon	Iron, Aluminium
Soot	Iron, Aluminium

**More reliable**

**More sustainable**

**More profitable**

Learn from a

Listen to a podcast from a

Get help from a

Become a

Find a

Learn from a

Listen to a podcast from a

Get help from a



# LUBRICATION EXPERT

[youtube.com/lubricationexplained](https://www.youtube.com/lubricationexplained)

<https://lubrication.expert>

[rafe@lubrication.expert](mailto:rafe@lubrication.expert)